



Operational Manual

Icetubs



© 2026 Icetubs B.V. All rights reserved.
This manual applies to Icetubs.
Version: 1.2 Last updated: March 2026

Publisher: Icetubs B.V., Amsterdam, The Netherlands
Email: info@icetubs.com | Website: www.icetubs.com

Icetubs reserves the right to make changes to this product or manual without prior notice.
No part of this publication may be reproduced or transmitted without written permission from Icetubs B.V.

Table of Content

1. Introduction	5
1.1. Purpose of This Manual	6
1.2. Importance of Reading the Manual	6
2. Product Overview	7
2.1. Product Description	8
2.2. Technical Specifications IceBarrel	10
2.3. Technical Specifications IceBarrel with Stairs	12
2.4. Technical Specifications IceBarrel XL	14
2.5. Technical Specifications IceBarrel XL with Stairs	16
2.6. Technical Specifications IceBath	18
2.7. Technical Specifications IceBath XL	20
2.8. Technical Specifications IceKube	22
2.9. Technical Specifications Cooling Engine	24
2.10. Technical Specifications Accessoires	25
2.11. Diagrams	26
3. Pre-Conditions for Safe Installation	27
3.1. Pre-Conditions for Safe Installation	28
4. Conditions for Safe Usage	29
4.1. General Safety Rules	30
4.2. Electrical Safety	30
4.3. Misuse Hazards & Prevention	30
4.4. Key Safety Warnings	31
5. Installation	32
5.1. Overall Information	33
5.2. Setting up the IceBarrel	34
5.3. Setting up the IceBarrel with Stairs	42
5.4. Setting up the IceBarrel XL	55
5.5. Setting up the IceBarrel XL with Stairs	63
5.6. Setting up the IceBath	76
5.7. Setting up the IceBath XL	85
5.8. Setting up the IceKube	92
5.9. Setting up the Phone Holder	100
5.10. First Test Run	101
5.11. Tips & Tricks After Installation	102

6. Cooling Engine Operation	103
6.1. Safety & Warnings	104
6.2. Precautions	105
6.3. Electrical Installation	105
6.4. Inspection	105
6.5. Display Operation	106
7. Maintenance & Water Hygiene	109
7.1. Requirements	110
7.2. Basic Principles of Hygiene	111
7.3. Maintenance To-Do List	112
7.3.1. Daily / after use – quick cleaning and checks	112
7.3.2. Weekly – water treatment & filter inspection	112
7.3.3. Monthly – filter replacement & water refresh (if needed)	112
7.3.4. Every 1–2 months (or as needed) — full water change & deep clean.	112
7.3.5. Expected lifespan of wear parts	113
7.3.6. Replace the filters	113
7.4. AquaFinesse Instruction Guide	114
7.5. Caring for ThermoWood Exterior	115
7.6. Thermo Cover Care	117
8. User Guidance	118
8.1. User Safety	119
8.1.1. Important to know	119
8.1.2. Before you start	119
8.1.3. During your session	119
8.1.4. After you've joined the cold	119
8.2. Contraindications & Risk Groups	120
9. Troubleshooting	122
9.1. How Troubleshooting Works	123
9.2. Troubleshooting “Water not cooling”	125
9.3. Troubleshooting “Problem with Water Level or Leaks”	126
9.4. Troubleshooting “Water Quality Not Good Enough”	127
10. Warranty & Service	128
10.1. Warranty	129
10.2. Approved Use for Warranty	129
10.3. Warranty Exclusions	129
10.4. Service	130
10.5. Warranty Transferability	131

1 Introduction

1.1 Purpose of This Manual

This manual is here to support you in getting the most out of your Icetub. It is written for everyone who works with the system or uses it at home. Inside, you'll find clear guidance for every stage: from deciding on the right setup, to installation, daily use, and long-term care. We explain what you need for installation, how to choose the best location, and how to keep both the water and the technical parts in good condition.

Each component, including the cooling engine, is described in simple, practical terms. Our aim is that you feel confident using, maintaining, and caring for your Icetub.

The goal of this manual is to give you the knowledge to use your Icetub safely, effectively, and with long-lasting satisfaction, whether at home or in a light-use professional environment.

1.2 Importance of Reading the Manual

This manual is an essential part of your Icetub experience. Taking the time to read it carefully ensures proper installation, safe use, and long-term performance. Incorrect installation or misuse can lead to damage, unsafe situations, and loss of warranty. Beyond installation, this manual shows you how to use and care for your Icetub correctly. Proper use and maintenance keep the system in optimal condition and help extend its lifespan.

In essence this manual helps you avoid mistakes, protect your Icetub, and enjoy it safely and confidently for years to come.

Product Overview

2.1 Product Description

The **Icetub** is a cold therapy system designed for private and light professional use. It combines durable tub construction with a **1 HP cooling engine**, digital temperature control, and app-based management for daily use.

2.1.1 Capacity

Designed for regular private and light professional use. Single-user operation per session.

2.1.2 Applications

The Icetub is designed for controlled cold-water immersion in residential environments and light professional setting. It supports a range of personal wellness and recovery applications when used in accordance with the instructions and safety guidelines provided in this manual.

Residential Use

The system is intended for private, non-commercial use in home settings. It is suitable for indoor or outdoor installation in residential environments where appropriate electrical supply, ventilation, and drainage are available.

Sports, Fitness, and Physical Recovery

The Icetub is commonly used by athletes and physically active individuals as part of post-exercise recovery routines. Typical applications include cold-water immersion following training or competition to support recovery and physical readiness.

Wellness and General Cold Exposure

The system may be used for personal wellness practices involving controlled cold exposure. Users may incorporate the ice bath into regular routines for adaptation to cold, mental resilience, or general well-being, based on individual tolerance and experience.

Contrast Therapy

The Icetub can be used as part of contrast therapy routines when alternated with heat exposure (e.g., sauna or hot shower).

When used in this context, users are responsible for determining appropriate exposure durations and temperatures based on personal condition and tolerance.

Intended User Profile

The product is intended for adult users in good general health who are familiar with cold-water immersion or who introduce cold exposure gradually. Users with underlying medical conditions should consult a qualified healthcare professional before use.

Non-Medical Use

This product is not a medical device and is not intended to diagnose, treat, cure, or prevent any disease or medical condition.

2.1.3 Unique features

Cooling and heating system:

- **1 HP cooling engine with integrated heater option**
- Advanced cooling engine with remote control, WiFi connectivity, and app-based temperature management.
- Supports **both cooling, heating and automatic modes**
- Temperature range: **as low as 3°C and up to 38°C** (with heater function purchased)

Water circulation and cleaning:

- Built-in circulation pump with a flow rate of **55 L/min**
- While the pump is running, a full water turnover and cleaning cycle occurs approximately every **6 minutes** (model-dependent, based on water volume)

Water management:

- Manual filling via garden hose
- Comes with a **Gardena hose attachment and drain valve**, allowing the bath to be drained easily on demand

Thermo insulation:

- Insulated Thermo cover
- High heat retention keeps water cold for long periods
- Energy-efficient operation: once temperature is reached, the engine requires minimal power to maintain it
- In automatic mode, the engine cycles infrequently due to insulation efficiency and stable temperature retention

Water treatment Ozone system:

- Built-in **ozone generation system**
- Ozone output range: **200–300 mg/h**
- Ozone breaks down organic contaminants and neutralises impurities
- Extends water usability and reduces the need for frequent draining
- Chemical-free cleaning (no chlorine required), although chlorine/bromine-free water treatment is recommended to further increase water lifespan.

Effective in cold water

- Ozone operation and status shown on controller (ozone icon)

Water filtration:

- The icebath features an integrated, replaceable mechanical filter designed to remove debris and particles from the circulating water. Regular inspection and timely replacement are required to maintain water clarity, hygiene, and system performance (See Chapter 7 for more information on instructions and frequency). For optimal fit and filtration efficiency, the use of manufacturer-approved replacement filters is required. Genuine replacement filters are available through our website and can be purchased individually or delivered on a recurring schedule.

Safety design:

- Power cable has a built in circuit breaker, if electricity leakage, short circuit is detected.

2.2 Technical Specifications IceBarrel

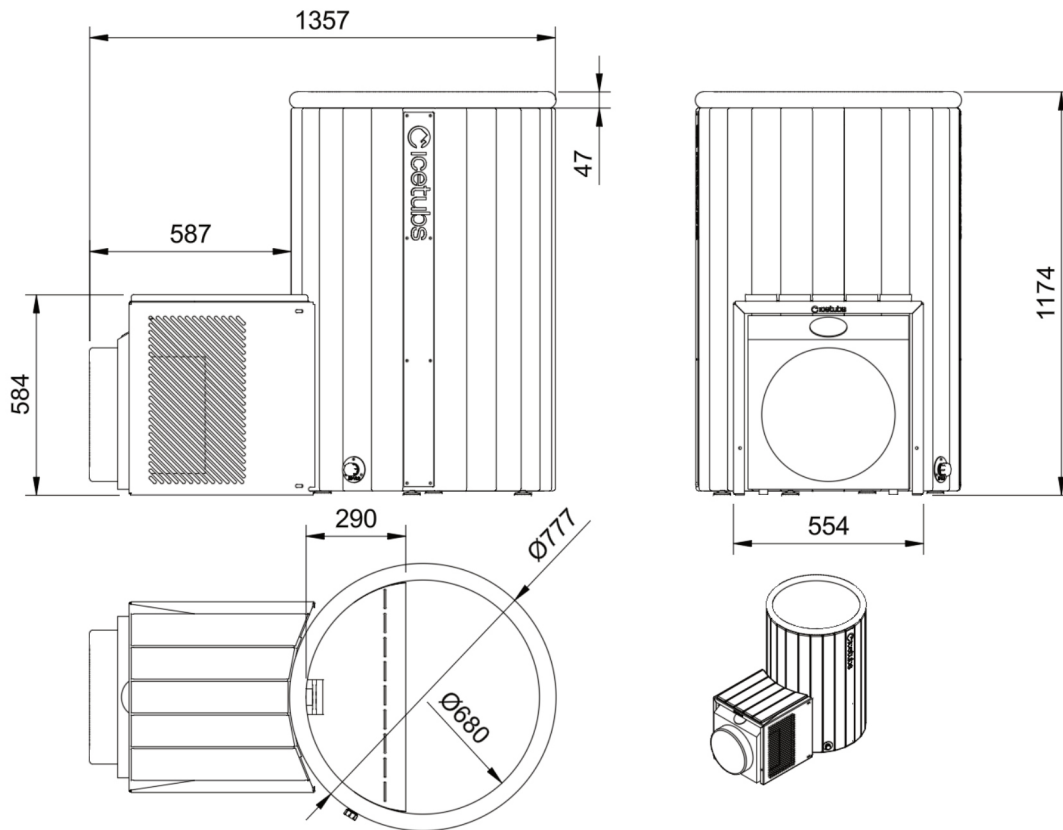

Parameter	Value
Height (mm)	1174
Length (mm)	1357
Width (mm)	777
Outer (mm)	777
Inner (mm)	680
Back recline (%)	674
Volume (L)	350
Weight (inc. Cooling Engine and protector) - Empty (kg)	148
Weight (inc. Cooling Engine and protector) - incl. water (kg)	498
Weight (inc. Cooling Engine and protector) - incl. packaging (kg)	170

2.2.1 Dimensions

- Length: approx. 1357 mm
- Width: approx. 777 mm
- Height: approx. 1174mm
- Height (with cover): 1264 mm

2.2.2 Weight

- Empty weight: approx. 148 kg (unit only).
- Filled with water and one user: approx. 578 kg total load.
- Distributed pressure: 1219 kg per m2 on the floor surface.

2.2.3 Capacity

- Water volume: approx. 350 liters.
- Suitable for one user..

2.2.4 Parts list

Quantity	Product
IceBarrel	
1x	IceBarrel
1x	Gardena hose attachment set
Cooling engine	
1x	Cooling engine
2x	Engine connector
4x	Rubber seals for engine connectors
1x	Cooling engine protector
Cover	
1x	Thermo cover
4x	Thermo cover clips
4x	Screws for Thermo cover clips
Maintenance products	
3x - 15x	9mm Filter (3 are included if bought through Shopify always, rest - optional)

2.3 Technical Specifications IceBarrel with Stairs

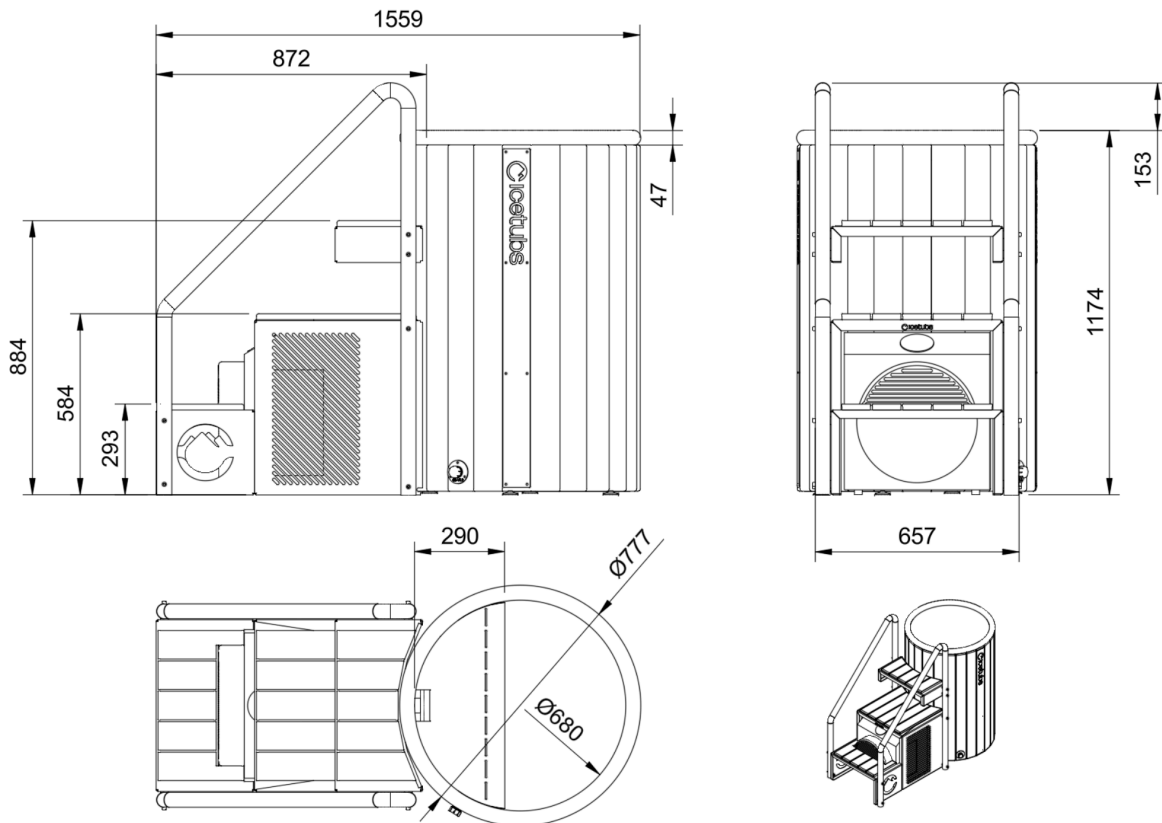

Parameter	Value
Height (mm)	1327
Length (mm)	1559
Width (mm)	777
Outer (mm)	777
Inner (mm)	680
Seating depth (mm)	674
Volume (L)	350
Weight (inc. Cooling Engine and protector) - Empty (kg)	172
Weight (inc. Cooling Engine and protector) - incl. water (kg)	522
Weight (inc. Cooling Engine and protector) - incl. packaging (kg)	194

2.3.1 Dimensions

- Length: approx. 1559 mm
- Width: approx. 777 mm
- Height: approx. 1327 mm
- Height (with cover): approx. 1327 mm (*Cover does not exceed the height of the stairs*)

2.3.2 Weight

- Empty weight: approx. 172 kg (unit only).
- Filled with water and one user: approx. 602 kg total load.
- Distributed pressure: 1270 kg per m² on the floor surface.

2.3.3 Capacity

- Water volume: approx. 350 liters.
- Suitable for one user..

2.3.4 Parts list

Quantity	Product
IceBarrel & Stairs	
1x	IceBarrel
1x	Gardena hose attachment set
Cooling engine	
1x	Cooling engine
2x	Engine connector
4x	Rubber seals for engine connectors
1x	Cooling engine protector
2x	Handrails for the stairs package
2x	Lower & upper step of the stairs package
4x	Screws for the stairs package.
Cover	
1x	Thermo cover
4x	Thermo cover clips
4x	Screws for Thermo cover clips
Maintenance products	
3x - 15x	9mm Filter (3 are included if bought through Shopify always, rest - optional)

2.4 Technical Specifications IceBarrel XL

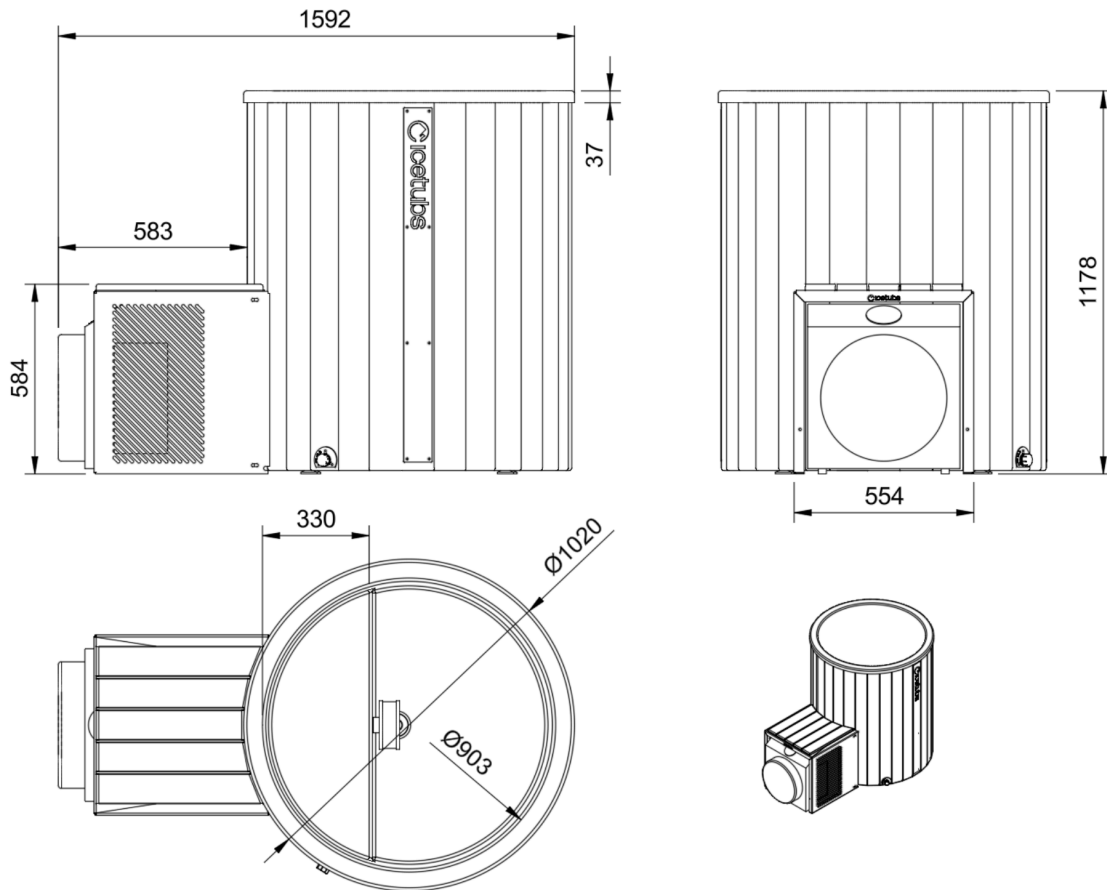

Parameter	Value
Height (mm)	1178
Length (mm)	1592
Width (mm)	1020
Outer (mm)	1020
Inner (mm)	903
Seating depth (mm)	655
Volume (L)	430
Weight (inc. Cooling Engine and protector) - Empty (kg)	169
Weight (inc. Cooling Engine and protector) - incl. water (kg)	599
Weight (inc. Cooling Engine and protector) - incl. packaging (kg)	191

2.4.1 Dimensions

- Length: approx. 1592 mm
- Width: approx. 1020 mm
- Height: approx. 1178 mm
- Height (with cover): 1268 mm

2.4.2 Weight

- Empty weight: approx. 169 kg (unit only).
- Filled with water and one user: approx. 679 kg total load.
- Distributed pressure: 831 kg per m² on the floor surface.

2.4.3 Capacity

- Water volume: approx. 430 liters.
- Suitable for one user.

2.4.4 Parts list

Quantity	Product
IceBarrel XL	
1x	IceBarrel XL
1x	Gardena hose attachment set
Cooling engine	
1x	Cooling engine
2x	Engine connector
4x	Rubber seals for engine connectors
1x	Cooling engine protector
Cover	
1x	Thermo cover XL
4x	Thermo cover clips
4x	Screws for Thermo cover clips
Maintenance products	
3x - 15x	9mm Filter (3 are included if bought through Shopify always, rest - optional)

2.5 Technical Specifications IceBarrel XL with Stairs

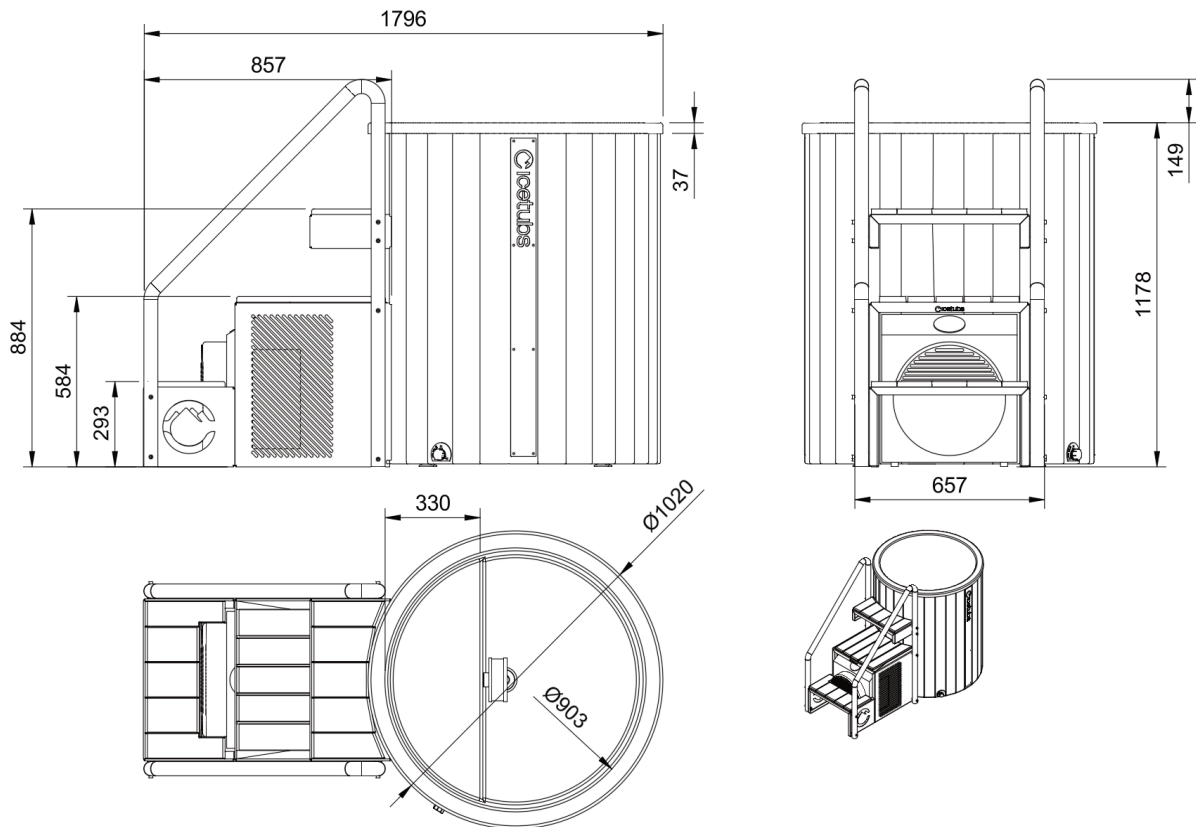

Parameter	Value
Height (mm)	1327
Length (mm)	1796
Width (mm)	1020
Outer (mm)	1020
Inner (mm)	903
Seating depth (mm)	655
Volume (L)	430
Weight (inc. Cooling Engine and protector) - Empty (kg)	193
Weight (inc. Cooling Engine and protector) - incl. water (kg)	623
Weight (inc. Cooling Engine and protector) - incl. packaging (kg)	215

2.5.1 Dimensions

- Length: approx. 1796 mm
- Width: approx. 1020 mm
- Height: approx. 1327 mm
- Height (with cover): 1327 mm (*Cover does not exceed the height of the stairs*)

2.5.2 Weight

- Empty weight: approx. 193 kg (unit only).
- Filled with water and one user: approx. 703 kg total load.
- Distributed pressure: 860 kg per m² on the floor surface.

2.5.3 Capacity

- Water volume: approx. 430 liters.
- Suitable for one user.

2.5.4 Parts list

Quantity	Product
IceBarrel XL & Stairs	
1x	IceBarrel XL
1x	Gardena hose attachment set
Cooling engine	
1x	Cooling engine
2x	Engine connector
4x	Rubber seals for engine connectors
1x	Cooling engine protector
2x	Handrails for the stairs package
2x	Lower & upper step of the stairs package
14x	Screws for the stairs package
Cover	
1x	Thermo cover XL
4x	Thermo cover clips
4x	Screws for Thermo cover clips
Maintenance products	
3x - 15x	9mm Filter (3 are included if bought through Shopify always, rest - optional)

2.6 Technical Specifications IceBath

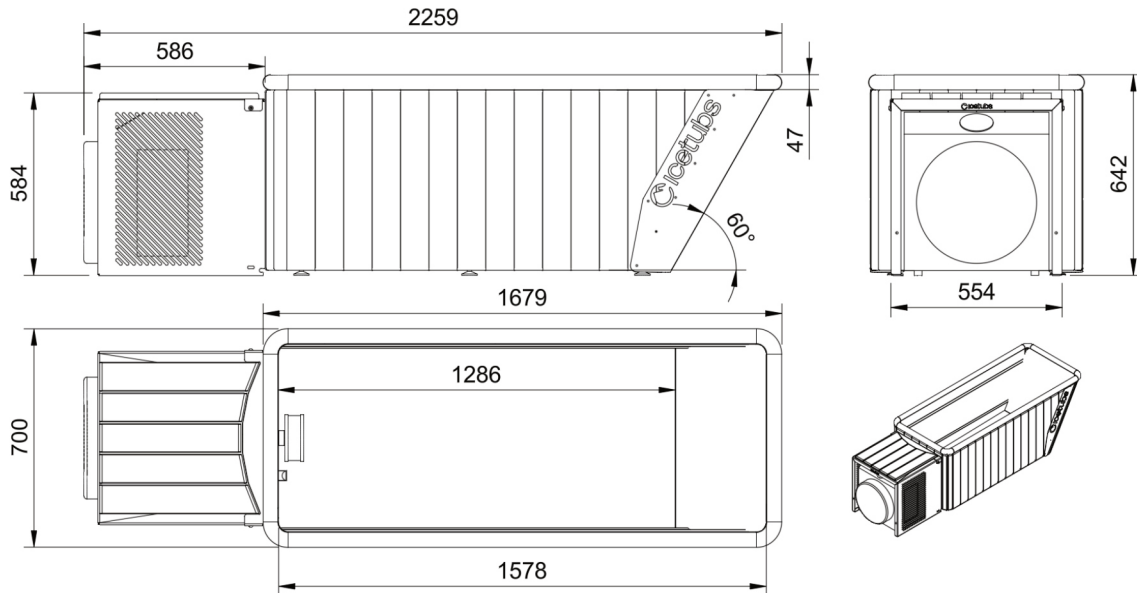

Parameter	Value
Height (mm)	642
Length (mm)	2259
Width (mm)	700
Outer (mm)	700
Inner (mm)	590
Back recline (%)	60
Volume (L)	400
Weight (inc. Cooling Engine and protector) - Empty (kg)	155
Weight (inc. Cooling Engine and protector) - incl. water (kg)	555
Weight (inc. Cooling Engine and protector) - incl. packaging (kg)	177

2.6.1 Dimensions

- Length: approx. 2259 mm
- Width: approx. 700 mm
- Height: approx. 642 mm
- Height (with cover): 732 mm

2.6.2 Weight

- Empty weight: approx. 155 kg (unit only).
- Filled with water and one user: approx. 635 kg total load.
- Distributed pressure: 403 kg per m² on the floor surface.

2.6.3 Capacity

- Water volume: approx. 400 liters.
- Suitable for one user.

2.6.4 Parts list

Quantity	Product
IceBath	
1x	IceBath
1x	Gardena hose attachment set
Cooling engine	
1x	Cooling engine
2x	Engine connector
4x	Rubber seals for engine connectors
1x	Cooling engine protector
Cover	
1x	Thermo cover
4x	Thermo cover clips
4x	Screws for Thermo cover clips
Maintenance products	
3x - 15x	9mm Filter (3 are included if bought through Shopify always, rest - optional)

2.7 Technical Specifications IceBath XL

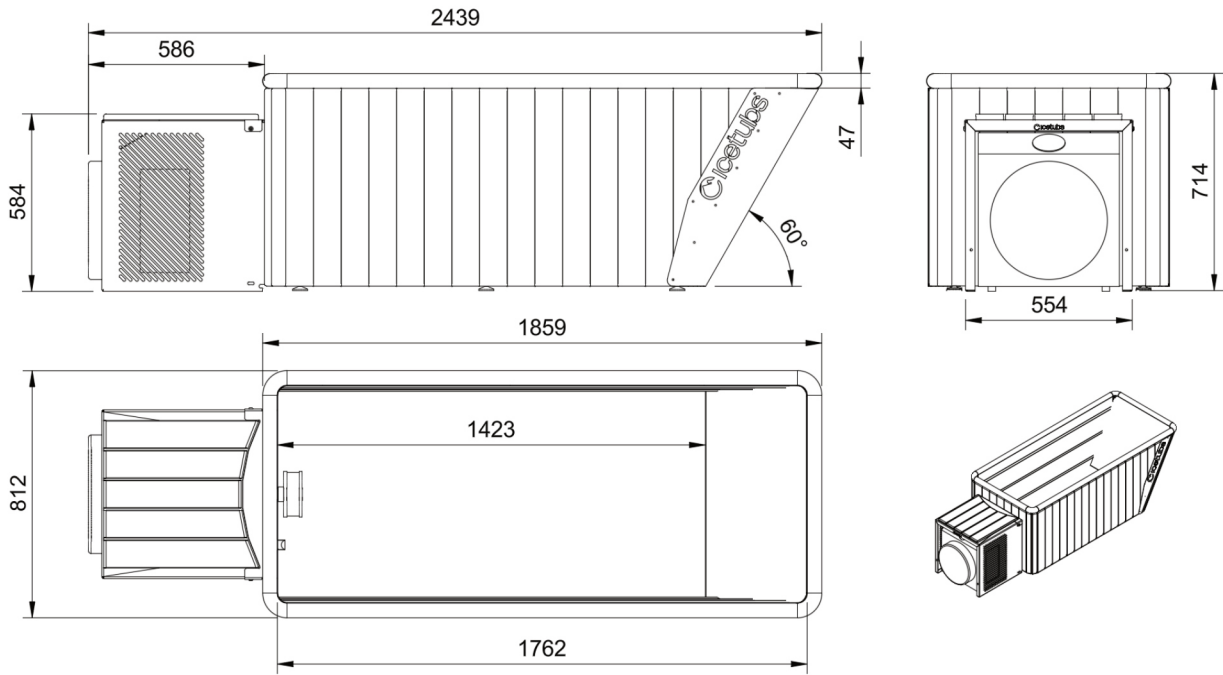

Parameter	Value
Height (mm)	714
Length (mm)	2439
Width (mm)	812
Outer (mm)	812
Inner (mm)	676
Back recline (%)	60
Volume (L)	500
Weight (inc. Cooling Engine and protector) - Empty (kg)	180
Weight (inc. Cooling Engine and protector) - incl. water (kg)	680
Weight (inc. Cooling Engine and protector) - incl. packaging (kg)	202

2.7.1 Dimensions

- Length: approx. 2439 mm
- Width: approx. 812 mm
- Height: approx. 714 mm
- Height (with cover): 804 mm

2.7.2 Weight

- Empty weight: approx. 180 kg (unit only).
- Filled with water and one user: approx. 760 kg total load.
- Distributed pressure: 386 kg per m² on the floor surface.

2.7.3 Capacity

- Water volume: approx. 500 liters.
- Suitable for one user.

2.7.4 Parts list

Quantity	Product
IceBath XL	
1x	IceBath XL
1x	Gardena hose attachment set
Cooling engine	
1x	Cooling engine
2x	Engine connector
4x	Rubber seals for engine connectors
1x	Cooling engine protector
Cover	
1x	Thermo cover
4x	Thermo cover clips
4x	Screws for Thermo cover clips
Maintenance products	
3x - 15x	9mm Filter (3 are included if bought through Shopify always, rest - optional)

2.8 Technical Specifications IceKube

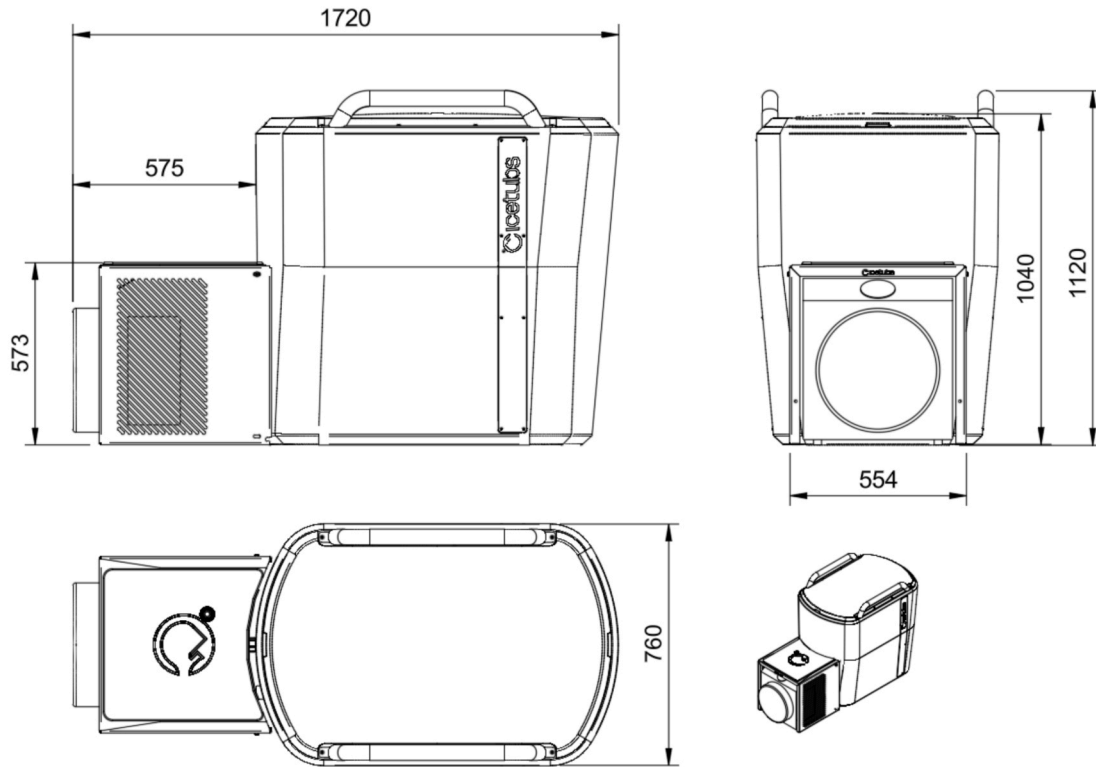

Parameter	Value
Height (mm)	1120
Length (mm)	1720
Width (mm)	760
Outer (mm)	760
Inner (mm)	606
Volume (L)	350
Weight (inc. Cooling Engine and protector) - Empty (kg)	100
Weight (inc. Cooling Engine and protector) - incl. Water (kg)	450
Weight (inc. Cooling Engine and protector) - incl. Packaging (kg)	125

2.8.1 Dimensions

- Length: approx. 1750 mm
- Width: approx. 760 mm
- Height: approx. 1120 mm
- Height (without handlebars): 1040 mm

2.8.2 Weight

- Empty weight: approx. 100 kg (unit only).
- Filled with water and one user: approx. 550 kg total load.
- Distributed pressure: 421 kg per m² on the floor surface.

2.8.3 Capacity

- Water volume: approx. 350 liters.
- Suitable for one user.

2.8.4 Parts list

Quantity	Product
IceKube	
1x	IceKube
1x	Gardena hose attachment set
Cooling engine	
1x	Cooling engine
2x	Engine connector
4x	Rubber seals for engine connectors
1x	Cooling engine protector
Lid	
1x	Lid
Maintenance products	
3x - 15x	9mm Filter (3 are included if bought through Shopify always, rest - optional)

2.9 Technical Specifications Cooling Engine

2.9.1 Power for the engine

- Electrical supply: 220–230 V / 50 Hz.
- Rated current: 7.5 A.
- Power consumption: approximately 1,7 kW at maximum output.
 - This peak consumption only occurs during intensive cooling down. The system does not run at maximum power continuously and will adjust automatically once the set temperature is reached.

2.9.2 Cooling

- Cooling capacity: 2-3.2 kW (2.18 kW Cooling capacity measured under following conditions: Ambient temperature = up to 30°C, Inlet water temperature = 20°C, Humidity = 50%).
- Temperature range: as low as 3°C.
- The entire water volume is cleaned and circulated every 6 minutes.
- Heat is expelled into the surrounding air; ambient temperature must not exceed 40°C for efficient cooling.

Parameter	Unit	Value
Cooling capacity	kW	2.18
Power consumption	kW	1.35
Power supply	/	220V-/50Hz
Operation air temperature	°C	-5 - 40
Refrigerant	/	R32
Ozonater's ozone output	ppm	200-300
Flow rate of water pump	L/min	55
Noise level (1m)	dB(A)	60
Max. Power Input	kW	1.7
Max. Current	A	7.5
Advised Water flow	m ³ /h	2
Water Pressure Drop	kPa	14

2.10 Technical Specifications Accessories

2.10.1 Phone holder

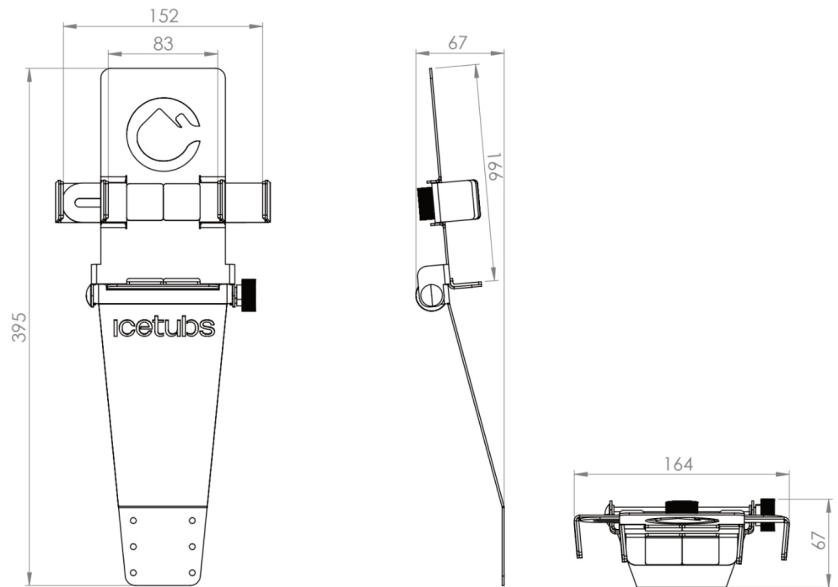

2.10.2 Dimension

- Length: approx. 395 mm
- Width: approx. 152 mm
- Depth: approx. 67 mm

2.10.3 Weight

- Weight: approx. 0.7 kg (unit only).

2.10.4 Capacity

- Suitable for one phone/tablet with maximum width of 28 cm.

2.10.5 Parts list

Quantity	Product
Phone holder	
1x	Phone holder
6x	Screws
1x	Mini star screwdriver

2.11 Diagrams

2.11.1 Electrical diagram

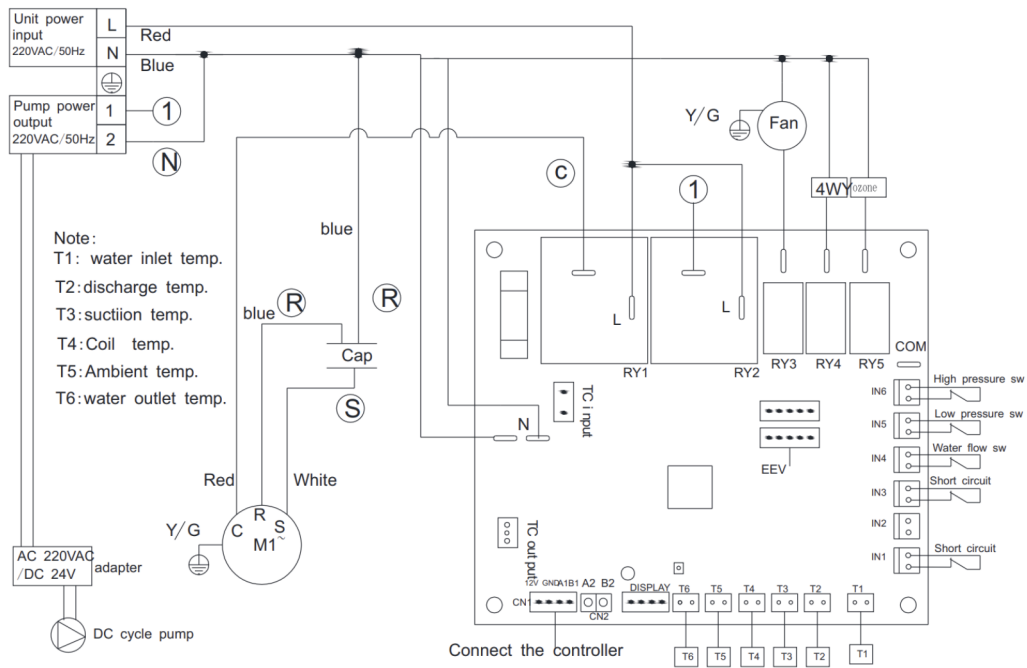

2.11.2 Water diagram

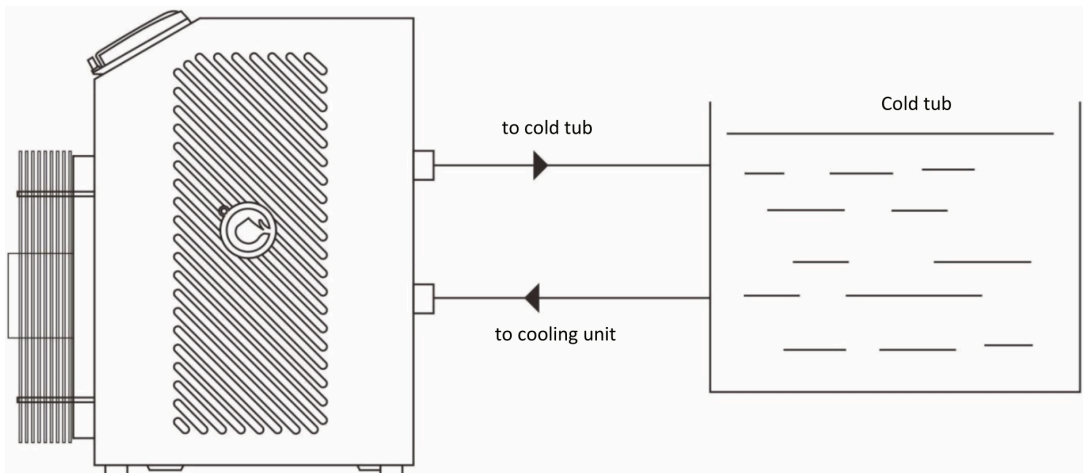

Pre- Conditions for Safe Installation

3.1 Pre-Conditions for Safe Installation

Before installing/receiving the Icetub, several points are important to pay attention to. These points will help you prepare everything for the installation.

- Distributed pressure from 386 kg (IceBath) to 403 kg (IceBath XL) per m² on the floor surface for IceBath products
- Distributed pressure from 831 kg (IceBarrel) to 1270 kg (IceBarrel with stairs) per m² on the floor surface for IceBarrel products
- The electrical socket should be grounded. If extension cord is used, the same grounding pin type should be used, so grounding is not lost when an extension cord is being used with the product.
- Ambient temperature should not fall below -5°C or go above 40°C (either inside or outside)
- Icetubs products should not be placed on dirt or synthetic grass, but on a concrete slab or wooden cladding, or any other surface that doesn't hold moisture. Moisture can climb up the wood, and the quality of the wood will worsen faster if this is not taken into account.
- Icetubs products should not be placed near a chlorinated pool or used with water treatment that has chlorine/bromine or salts, as it can compromise the steel quality over time and cause corrosion (pitting, rust).
- If Icetubs products are in a salty environment, for example within 20km of the sea, Icetubs products should regularly be rinsed with fresh water, to avoid salt overtime corroding the steel.
- Icetubs Cooling Engine should not be left under the rain unprotected, as it can cause a short circuit. To prevent this, the cooling engine power cable's circuit breaker (small box on the cable) should be protected from exposure to water.

4 Conditions for Safe Usage

4.1 General Safety Rules

- Ensure the building floor can support the Icetubs full weight when filled and in use (approx. from 578 kg to 760 kg taking into account average weight of 1 person).
- Install only on a stable, flat, and level surface. Use the adjustable feet if needed to level the Icetub and align the connectors with the engine.
- Keep at least 50 cm of clearance around the cooling engine for ventilation.
- The installation room must be well ventilated to allow hot air to escape and cool air to flow in. Ambient temperature must not exceed 40°C during summer months or be below -5°C degrees during winter months if it's outside.
- Always check that filters are installed and submerged before starting the engine.
- Only use approved accessories and chemicals as described in this manual. See section 7 for maintenance and water hygiene for exact requirements.
- Icetubs products should not be placed on dirt or synthetic grass, but on a concrete slab or wooden cladding, or any other surface that doesn't hold moisture. Moisture can climb up the wood, and the quality of the wood will worsen faster if this is not taken into account.
- Icetubs products should not be placed near a chlorinated pool or used with water treatment that has chlorine/bromine or salts, as it can compromise the steel quality over time and cause corrosion (pitting, rust).
- Icetubs products placed outside within a salty environment (within 20km of the sea, for example), should be rinsed every few days so the salt doesn't compromise the coating of the steel over time and cause rust.

4.2 Electrical Safety

- Connect the Icetub to a properly grounded electrical circuit. (If it's connected to an extension cord, make sure the grounding pins are the same type)
- Keep all electrical components dry and protected from moisture. Do not spray water directly on the engine housing/ cable or connections. Protect these components from rain if it's outside. (especially the cable's circuit breaker box)
- Inspect the power cord regularly. Do not use it if damaged.
- Never operate the unit without proper grounding, as this may cause electric shock.

4.3 Misuse Hazards & Prevention

- Do not operate without water: running the engine dry can cause serious damage which is not covered under warranty.
- Do not add unauthorized chemicals: use only ozone, chlorine/bromine-free water treatment.

- Do not block ventilation zones: obstructing airflow may cause overheating or motor failure.
- Do not attempt to open or modify the engine: this voids warranty and can cause injury.
- Do not use contaminated or unclear water: always ensure filters are maintained and replaced regularly.
- Do not exceed safe exposure times: prolonged immersion in extreme cold can cause hypothermia.
- **Important!** Do not dissolve any chlorine, salts, or acid-containing materials in the water, nor clean the tub with these substances or any other (harsh) chemicals.

4.4 Key Safety Warnings

Do's

- Read the manual carefully before first use to understand installation, operation, and maintenance requirements.
- Check the water level before each session.
- Inspect the water quality to ensure it is clean and clear; it might be helpful to replace the filter more often than required (once every month).
- Verify the temperature setting on the controller or app before entering.
- Ensure safe access by confirming the entry area is dry and stable.
- Confirm power connections are secure and properly grounded.
- Supervise first-time users and explain safe entry, exit, and duration of use.

Don'ts

- Do not allow direct access to the cooling engine. The engine protector must remain in place at all times.
- Do not use the bath if water appears contaminated (cloudy, oily, or with visible dirt) until filtration and cleaning is completed, or full water change is done.
- Do not add unauthorized chemicals to the water; only approved products recommended in the manual should be used.
- Do not exceed recommended usage times for cold exposure.
- Do not allow children or medically at-risk individuals to use the bath without medical advice or supervision.
- Do not operate the system without water, this may damage the cooling engine and pumps.
- Do not block ventilation openings around the engine housing, this can cause overheating. Complete installation exactly as described in section 4.

Installation

5.1 Overall Information

The way the water cools down in the Icetub is by extracting the heat from it. Our unique cooling system has been designed to remove the heat from the water and send that heat into the air around it. This means the cooling engine makes warm air in the room the Icetub is placed in, while keeping the temperature in it cold. When placed indoors, it's important to note that the warm air needs to leave the room through good ventilation or air conditioning for the cooling engine to efficiently operate. When the engine runs at full power, it produces about **2.5 kW** of heat. Which means, when placed inside, it blows this heat into the room. This is why it's important to cool the room where the Icetub is placed. We would like to remind you that the ambient temperature in the room must **never exceed 40 °C or fall below -5 °C** (1°C if the engine is not working 24/7) . If any components fail due to operation outside this range, **warranty coverage may be voided**.

5.2 Setting up the IceBarrel

Step 1. Unpacking

- Remove the zip ties and take out the cardboard boxes and protective materials.
- Keep the engine standing for 24h before operation
- Immediately inspect for any damage. If you notice anything, contact us at: service@icetubs.com

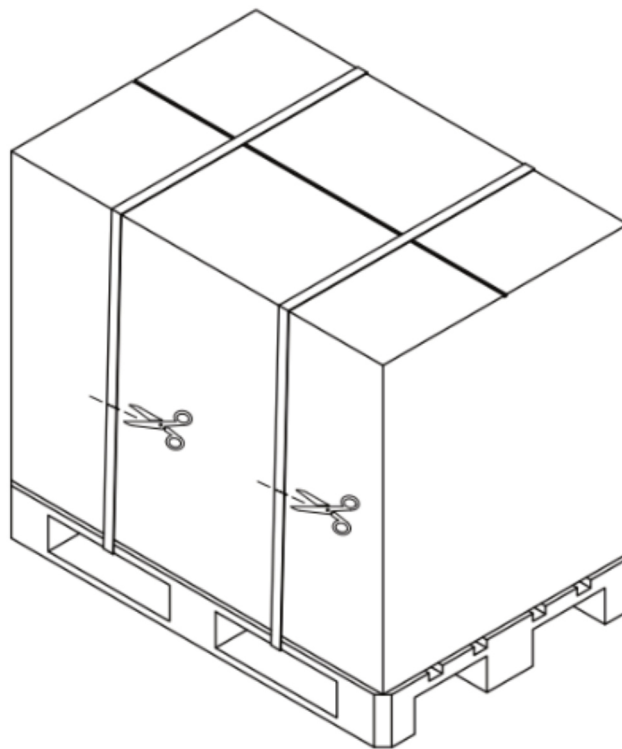

Step 2. Position the Components

- Place the barrel and cooling unit in their designated spots. (See 2.1 Figure)
Tip: Ensure the environment is well ventilated.
- **Weight:** A filled IceBarrel with one person = approx. **578 kg**.
 - Spread across 0,474 m² → **1219 kg/m²** load.
- **Check load capacity:** Ensure the building structure can safely support this weight.

Cooling motor clearance:

- The cooling engine expels heat into the room, which needs to be regulated following the instructions mentioned in point '4. Conditions for Safe Usage.'
- It's important that when setting up the Icetub there is at least eave **50 cm clearance** around the engine protector.

2.1 Figure. Positioning of IceBarrel & Cooling Engine.

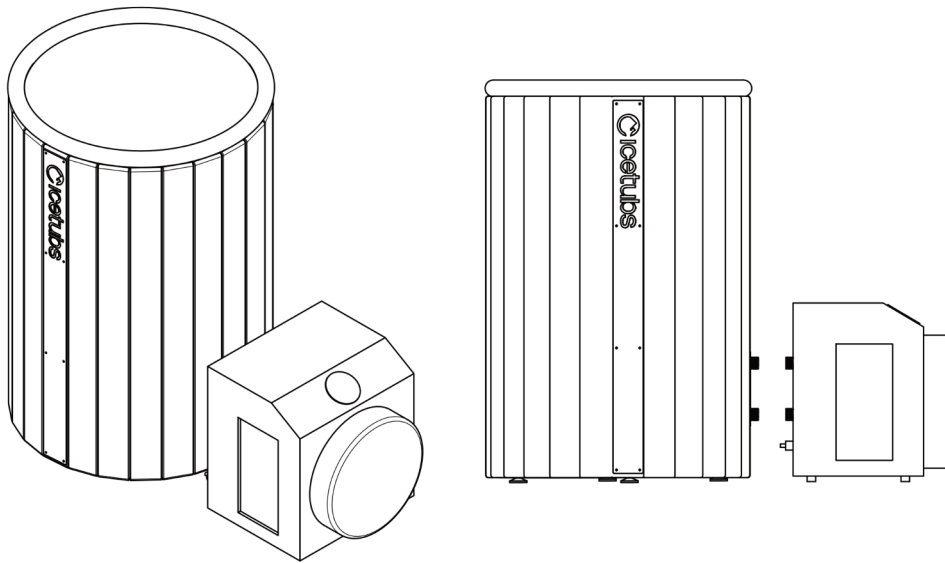

Step 3. Level the Tub and Cooling Unit

- Align the cooling unit’s inlet and outlet with the connections on the Icetub, then adjust the leveling feet under both the Icetub and the cooling unit with a 16 mm wrench for Icetubs until they are perfectly aligned and stable.

Step 4. Attach the Engine connectors

- Attach the two engine connectors with rubber seals to the lower inlet and top outlet of the water loop between the engine and the Icetub (See 4.1 Figure). Please note that the rubber seals were provided with the engine connectors.
- Attach the other ends of the connectors, also with rubber rings in place, to the cooling unit.

Note: Do not turn on the cooling unit yet!

4.1 Figure. Engine Connectors’ location.

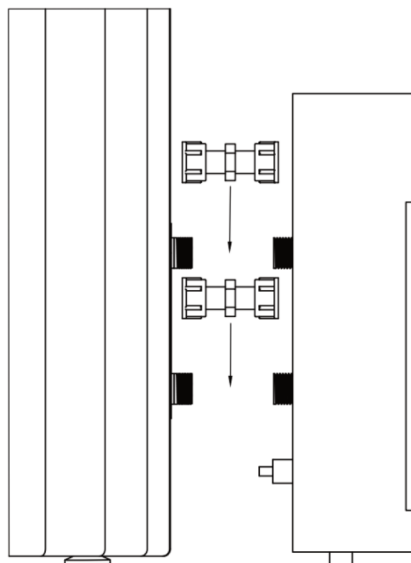

5.1 Figure. Rinsing the IceBarrel.

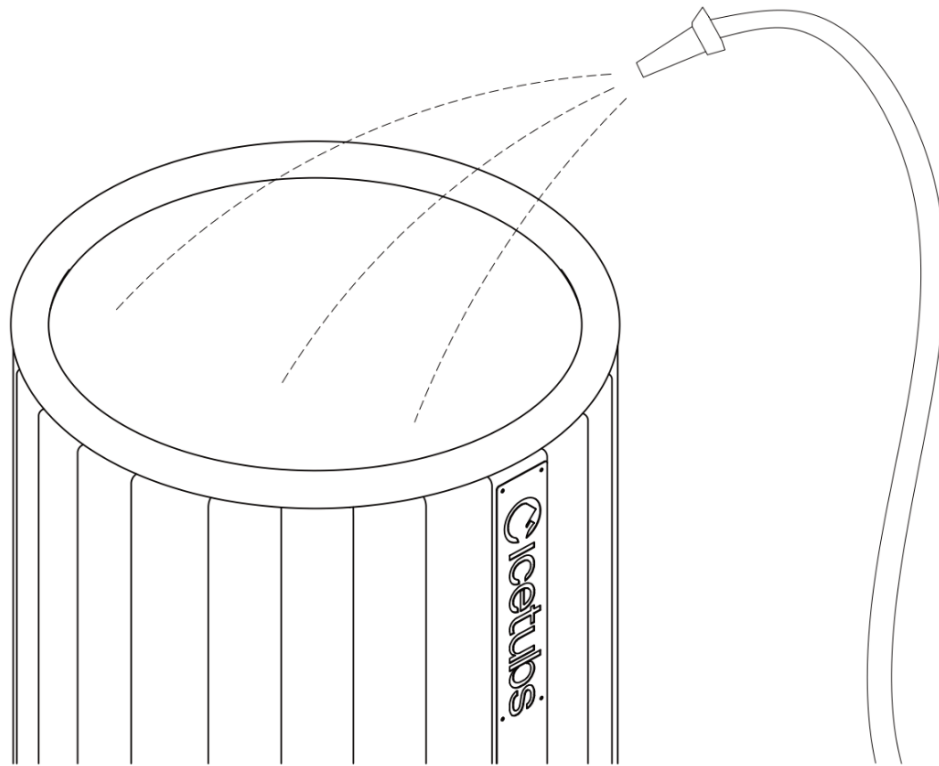

5.2 Figure. Gardena Drain Hose Attachment.

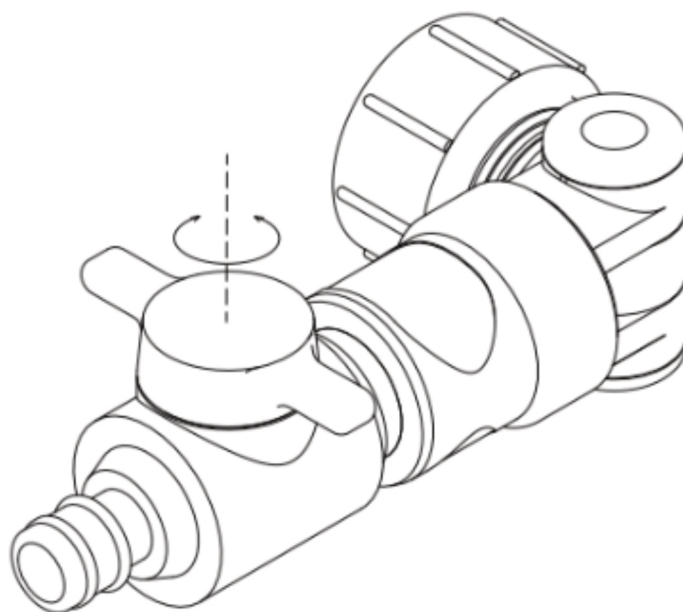

Step 6. Prepare the Barrel

- Once the water level reaches the **top outlet of the water** loop between the cooling unit and the Icetub, flush out any air from the system:
 - Hold your **garden hose** against the **top outlet and then bottom inlet** separately to push out air.
 - Fully **submerge the filter** under water in the Icetub to release all trapped air.
 - Screw the filter onto the **bottom connection (inlet) of the water loop inside the Icetub**. This prevents debris from entering the system and ensures smooth operation. (See 6.1 Figure)

Important note: Never use Icetubs without a filter installed, as this will result in engine failure over time and voids warranty!
- Install the metal seat that goes above the filter. (See 6.2 Figure)
- Check that all connectors are watertight and not dripping water. Tighten further if necessary. (See 6.3 Figure)
- Fill the Icetub with water up to **20 cm from the rim**, considering your body weight and height. (See 6.4 Figure)

6.1 Figure. Installing the Filter on the lower inlet in the IceBarrel.

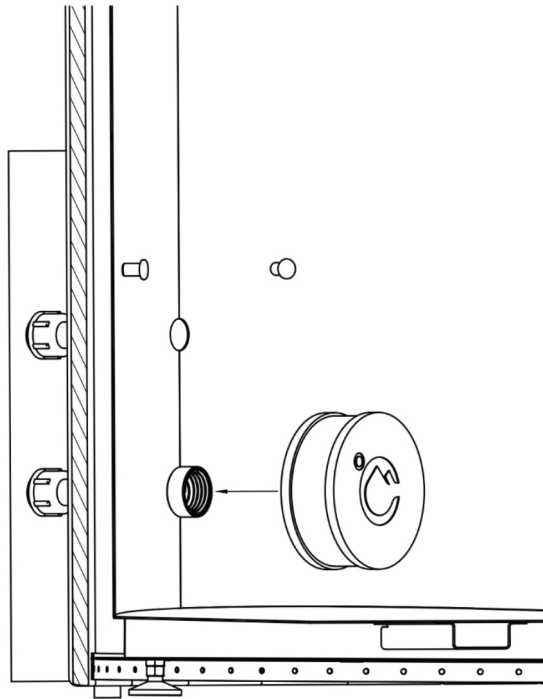

6.2 Figure. Metal seat's location in the IceBarrel.

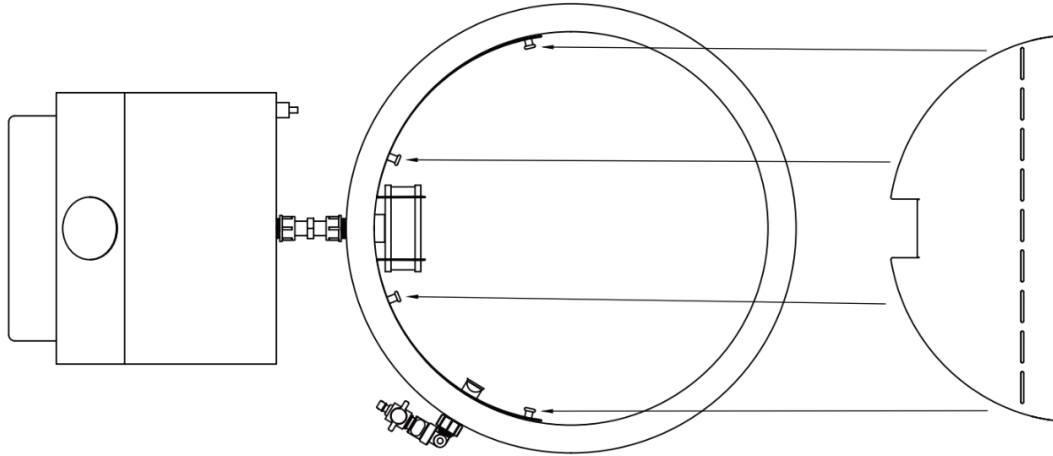

6.3 Figure. Leakage checking.

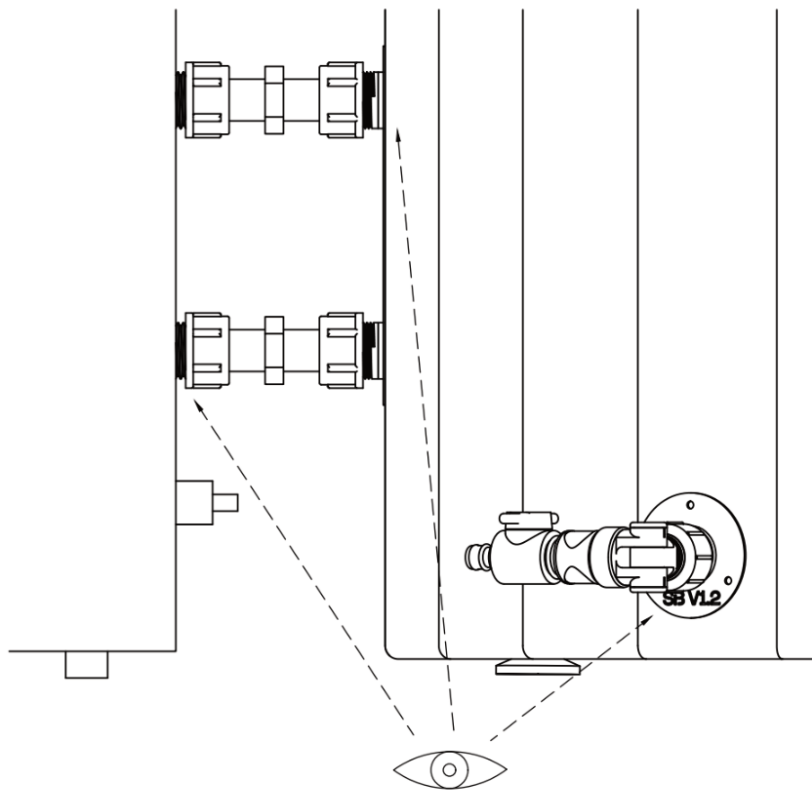

6.4 Figure. Filled IceBarrel.

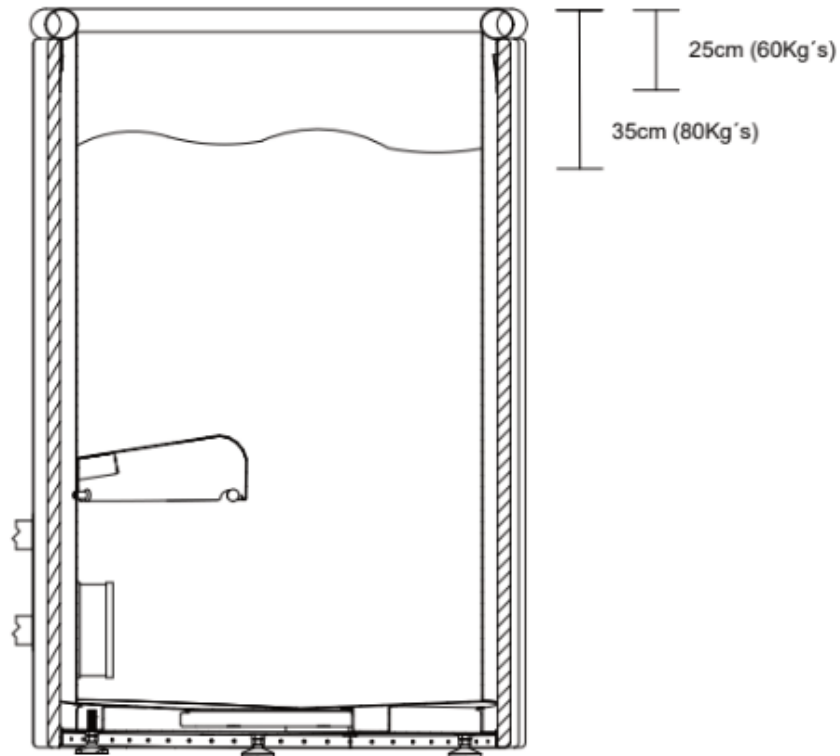

Step 7. Prepare the Barrel

- Plug the cooling unit into a grounded outlet. Ensure the small box that's on the cable (**circuit breaker**) is **hanging against the wall** and not lying on the ground.
Important: The power cable and the circuit breaker is **water-resistant, not waterproof**, if your setup is outdoors, you must ensure that is **protected from rain and direct moisture**. (See 7.1 Figure)
- Press the **“ON”** button to turn on the cooling unit. Confirm that the circuit breaker is in the **ON** position. (See 7.2 Figure)
- Set the engine Automatic mode by pressing the **“M”** button until the **‘AUTO’** mode appears. (Automatic mode is able to cool and heat the water at the same time) (See 7.3 Figure)
- Set your desired temperature using the **“↑”** and **“↓”** buttons.
- Use the Icetubs app to adjust the settings remotely (ensure the cooling unit is close to your router for a stable connection):
 - Download the application in **Google Play Store or App Store**
 - Follow the instructions in the app to connect your Icetubs engine and control it remotely.
- It's recommended to read the tips & tricks in the app on how to adjust your Icetubs usage routine to progress efficiently.

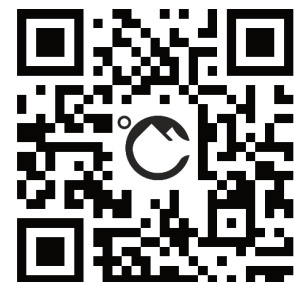

7.1 Figure. Electrical Outlet with grounding pins schematic.

Type F Socket

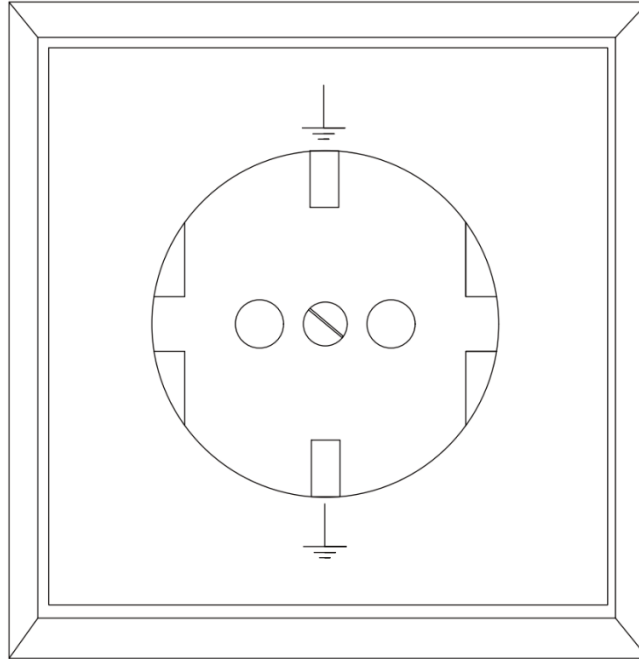

7.2 Figure. Cooling Engine's Control Panel. "ON" button highlighted.

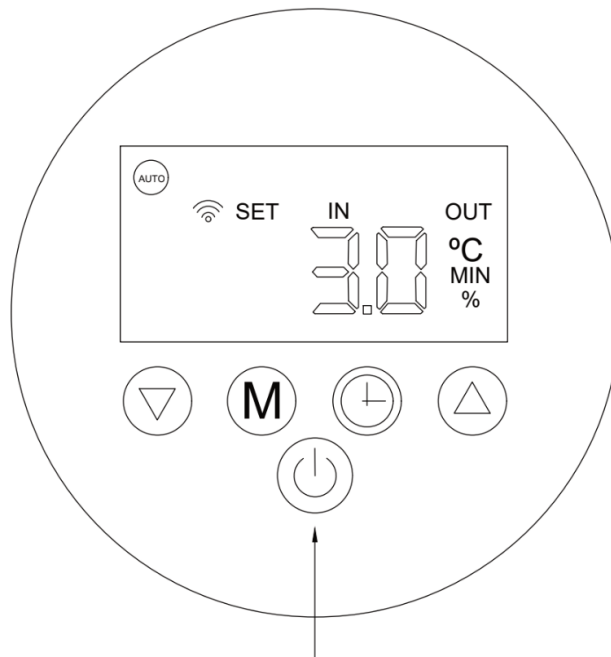

7.3 Figure. Cooling Engine’s Control Panel. “M” button highlighted.

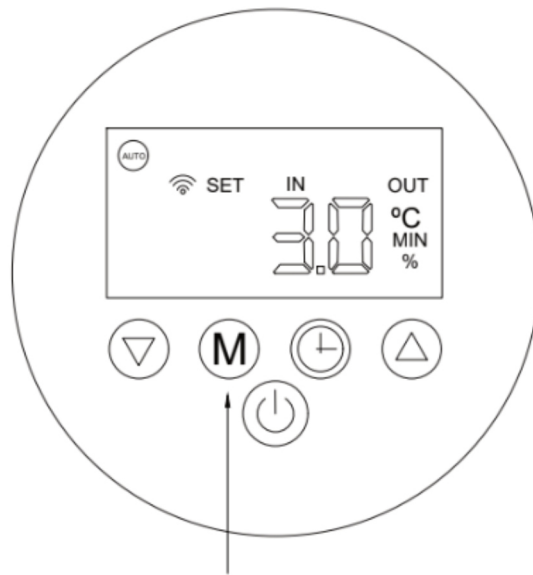

Step 7. Prepare the Barrel

- Place the engine protector over the cooling unit and the Icetub Thermo cover on top.
Important: If your Icetub is placed **outside**, it’s recommended to **screw in the Icetubs Thermo cover clips** into the wood to prevent it from being swept away by wind. The screws should go in the **middle of the board**. (See 8.1 Figure & 8.2 Figure)
- If you purchased the **AquaFinesse Water Treatment All-in-One**, add the **weekly dosage** only **after** the Icetub has been filled. Then continue adding the weekly dosage every week. Dosage instructions can be found on support.icetubs.com.

8.1 Figure. Installing the Barrel’s Cover.

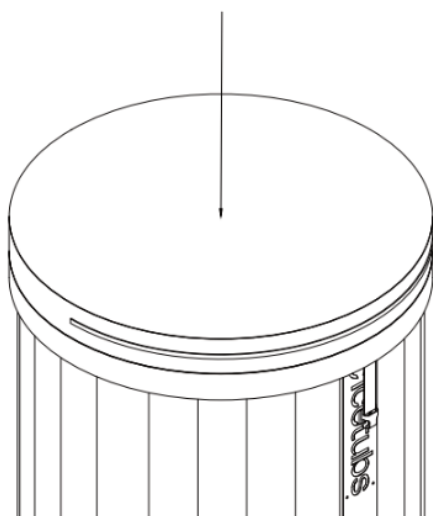

8.2 Figure. Cooling Engine’s Protector.

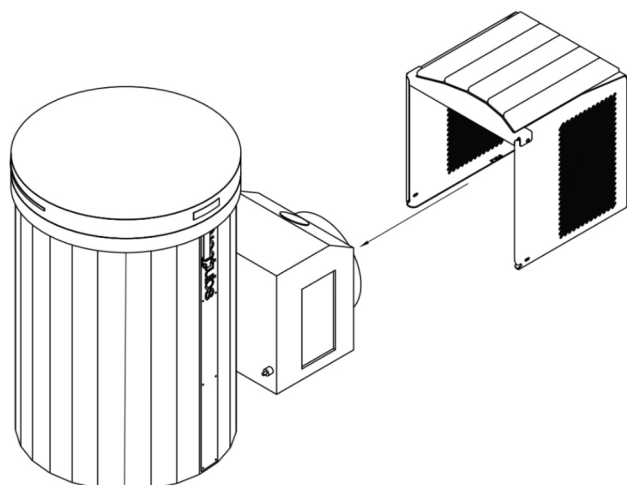

5.3 Setting Up the IceBarrel with Stairs

Step 1. Unpacking

- Remove the zip ties and take out the cardboard boxes and protective materials.
- Keep the engine standing for 24h before operation
- Immediately inspect for any damage. **If you notice anything, contact us at: service@icetubs.com**

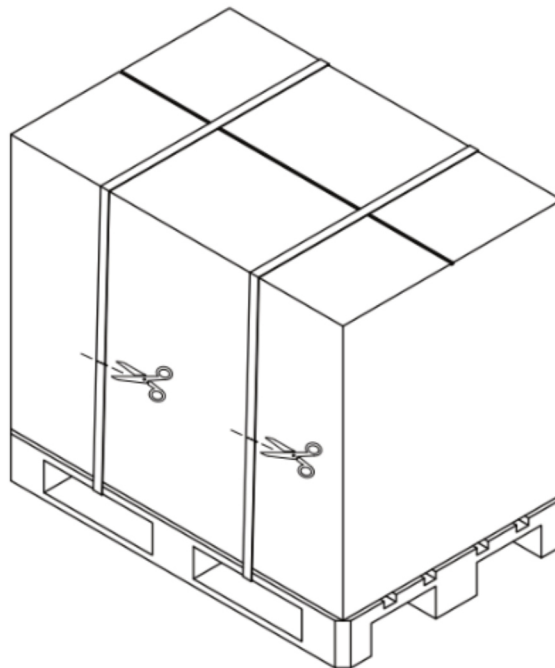

Step 2. Position the Components

- Place the barrel and cooling unit in their designated spots. (See 2.1 Figure)
Tip: Ensure the environment is well ventilated.
- **Weight:** A filled IceBarrel with one person = approx. **578 kg**.
 - Spread across 0,474 m² → **1219 kg/m²** load.
- **Check load capacity:** Ensure the building structure can safely support this weight.

Cooling motor clearance:

- The cooling engine expels heat into the room, which needs to be regulated following the instructions mentioned in point '4. Conditions for Safe Usage.'
- It's important that when setting up the Icetub there is at least also **50 cm clearance** around the engine protector.

2.1 Figure. Positioning of IceBarrel & Cooling Engine.

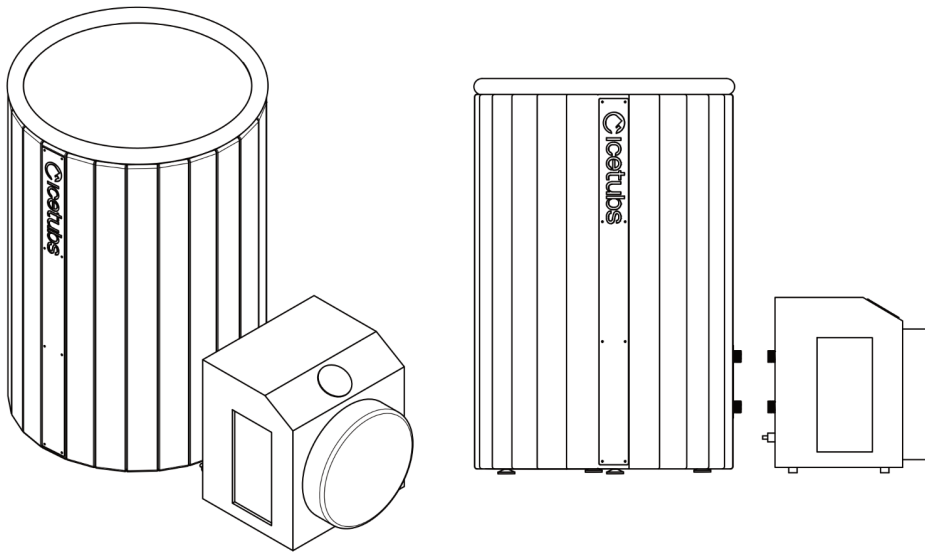

Step 3. Level the Tub and Cooling Unit

- Align the cooling unit's inlet and outlet with the connections on the Icetub, then adjust the leveling feet under both the Icetub and the cooling unit with a 16 mm wrench for Icetubs until they are perfectly aligned and stable.

Step 4. Attach the Engine connectors

- Attach the two engine connectors with rubber seals to the lower inlet and top outlet of the water loop between the engine and the Icetub (See 4.1 Figure). Please note that the rubber seals were provided with the engine connectors.
- Connect the other ends of the connectors, also with rubber rings in place, to the cooling unit.

Note: Do not turn on the cooling unit yet!

4.1 Figure. Engine Connectors' location.

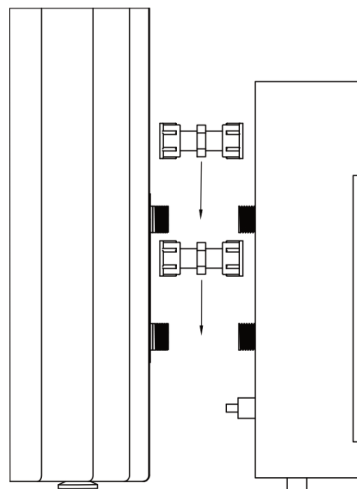

Step 5. Rinse the IceBarrel

- Remove the cap from the drain pipe, rinse the tub thoroughly, and drain the water completely. (See Figure 5.1)
- (Optional but recommended) Install the **drain attachment** provided together with the Icetubs for easier draining in the future. Make sure it's not left open before filling up the IceBarrel.(See Figure 5.2)
- If drain attachment is not installed, reinstall the cap of the drain pipe.

5.1 Figure. Rinsing the IceBarrel.

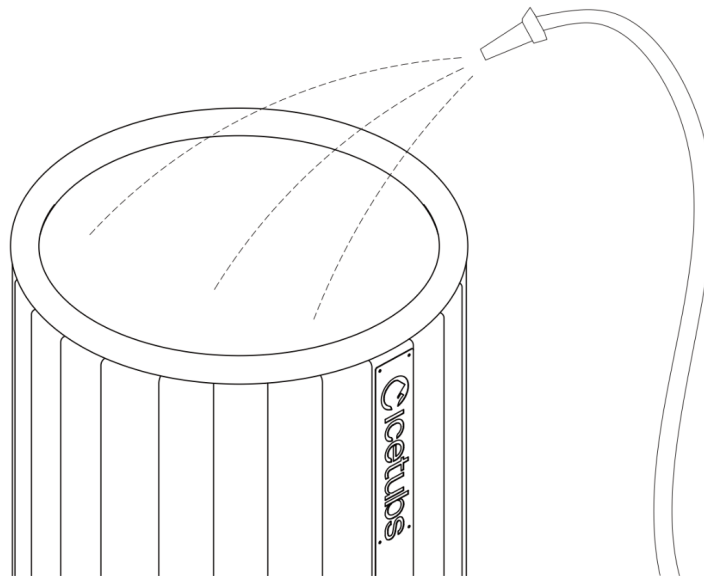

5.2 Figure. Gardena Drain Hose Attachment.

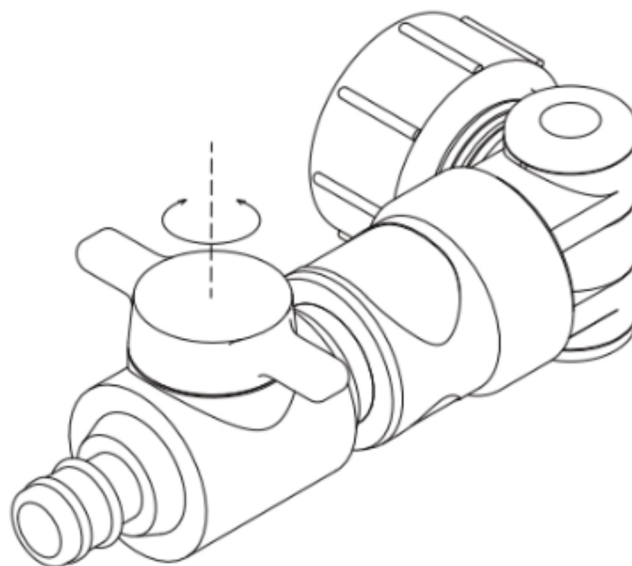

Step 6. Prepare the IceBarrel

- Once the water level reaches the **top outlet of the water loop** between the cooling unit and the Icetub, flush out any air from the system:
 - Hold your **garden hose** against the **top outlet and then bottom inlet** separately to push out air.
 - Fully **submerge the filter** under water in the Icetub to release all trapped air.
 - Screw the filter onto the **bottom connection (inlet) of the water loop inside the Icetub**. This prevents debris from entering the system and ensures smooth operation. (See 6.1 Figure)

Important note: Never use Icetubs without a filter installed, as this will result in engine failure over time and voids warranty!
- Install the metal seat that goes above the filter. (See 6.2 Figure)
- Check that all connectors are watertight and are not dripping water. Tighten further if necessary. (See 6.3 Figure)
- Fill the Icetub with water up to **20 cm from the rim**, considering your body weight and height. (See 6.4 Figure)

6.1 Figure. Installing the Filter on the lower inlet in the IceBarrel.

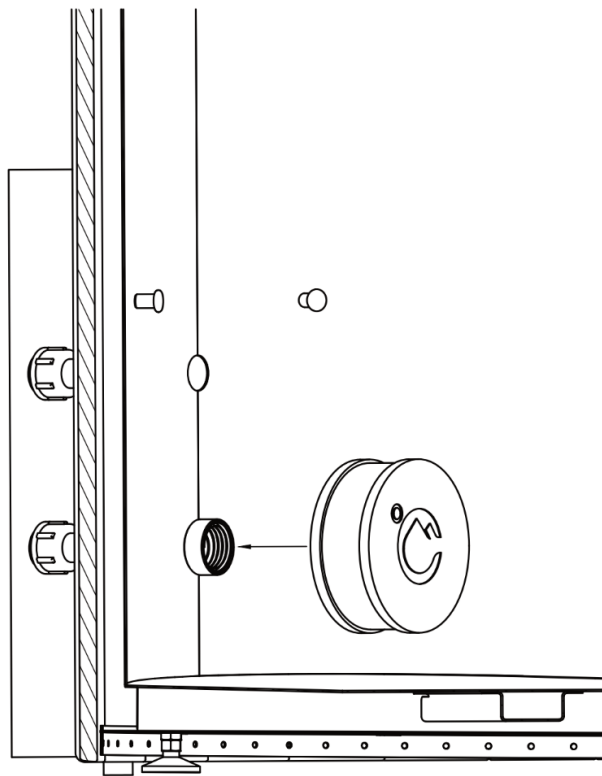

6.2 Figure. Metal seat's location in the IceBarrel.

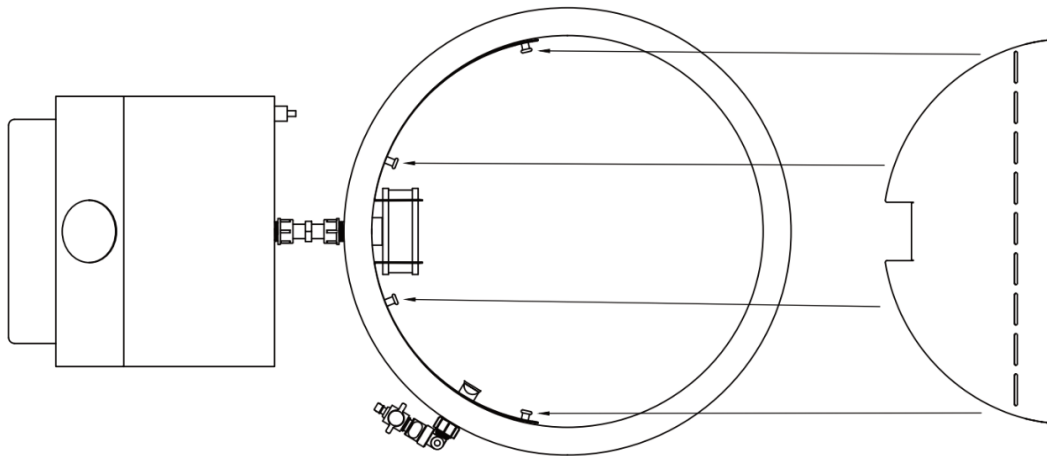

6.3 Figure. Leakage checking.

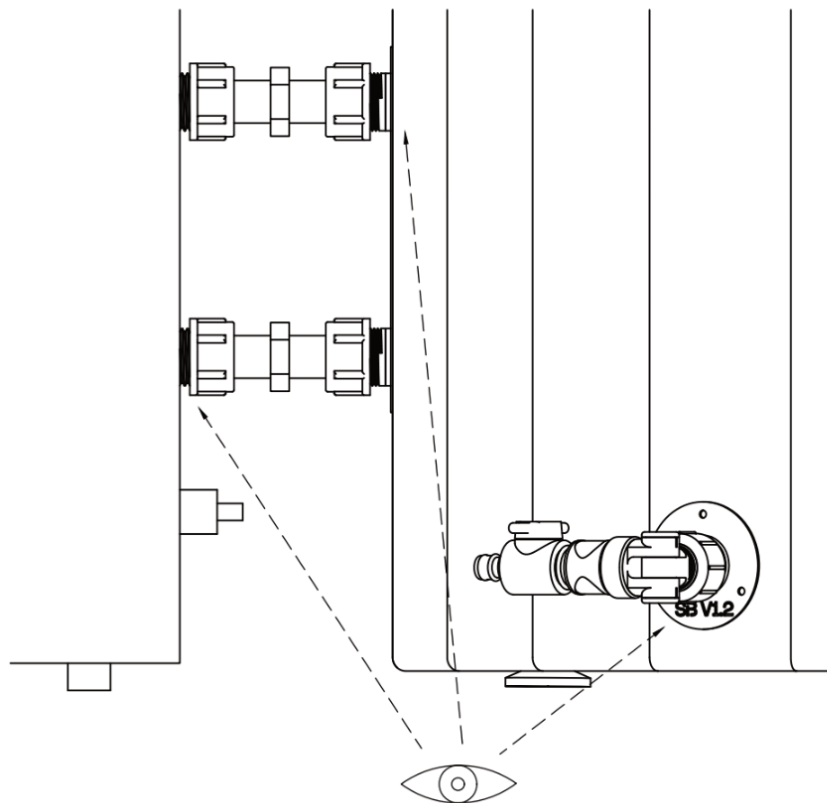

6.4 Figure. Filled IceBarrel.

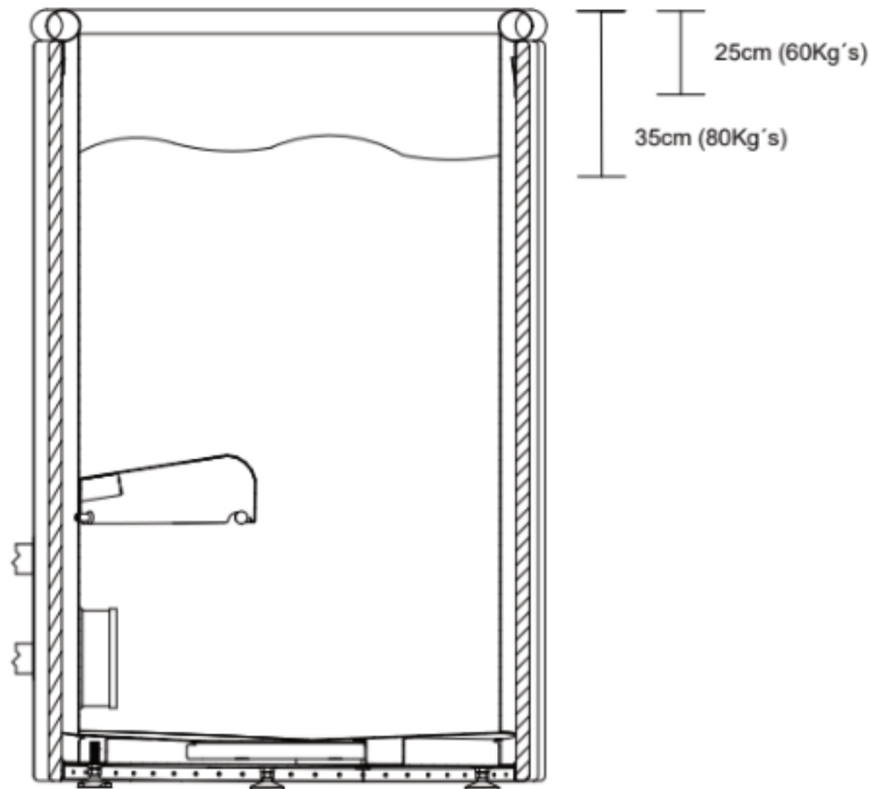

Step 7. Prepare the Barrel

- Plug the cooling unit into a grounded outlet. Ensure the small box that's on the cable (**circuit breaker**) is **hanging against the wall** and not lying on the ground.
Important: The power cable and the circuit breaker is **water-resistant, not waterproof**, if your setup is outdoors, you must ensure that is **protected from rain and direct moisture**. (See 7.1 Figure)
- Press the **“ON”** button to turn on the cooling unit. Confirm that the circuit breaker is in the **ON** position. (See 7.2 Figure)
- Set the engine Automatic mode by pressing the **“M”** button until the **‘AUTO’** mode appears. (Automatic mode is able to cool and heat the water at the same time) (See 7.3 Figure)
- Set your desired temperature using the **“↑”** and **“↓”** buttons.
- Use the Icetubs app to adjust the settings remotely (ensure the cooling unit is close to your router for a stable connection):
 - Download the application in **Google Play Store or App Store**
 - Follow the instructions in the app to connect your Icetubs engine and control it remotely.
- It's recommended to read the tips & tricks in the app on how to adjust your Icetubs usage routine to progress efficiently.

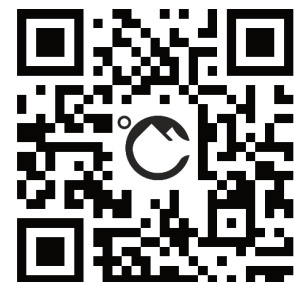

7.1 Figure. Electrical Outlet with grounding pins schematic.

Type F Socket

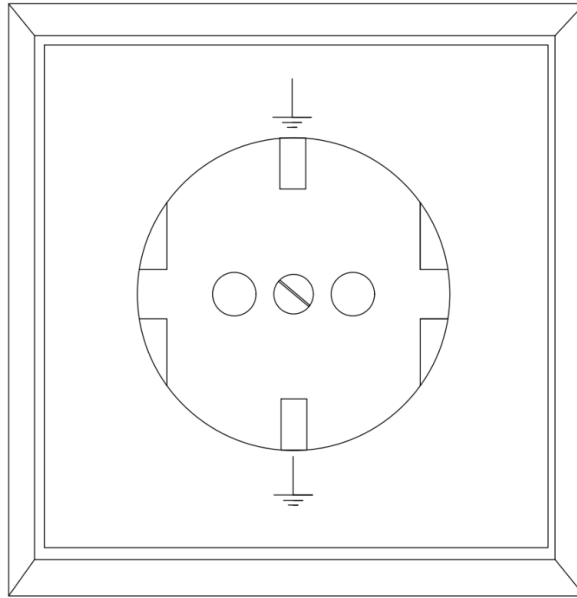

7.2 Figure. Cooling Engine's Control Panel. "ON" button highlighted.

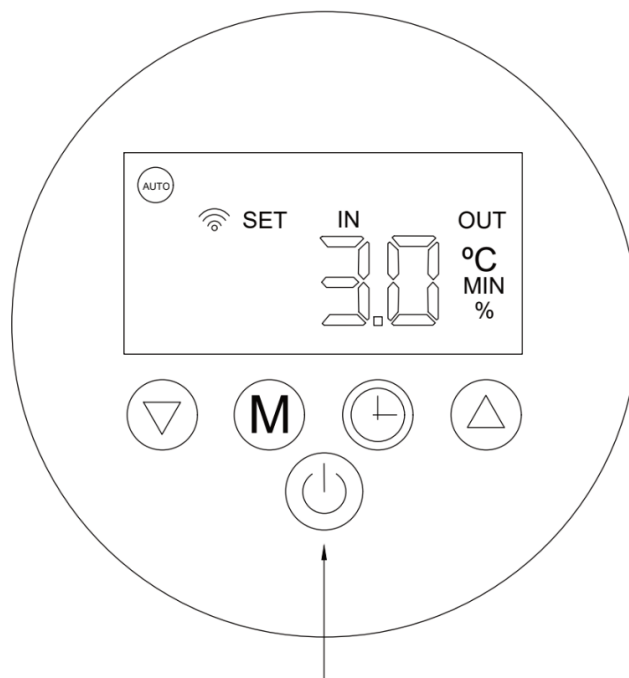

7.3 Figure. Cooling Engine’s Control Panel. “M” button highlighted.

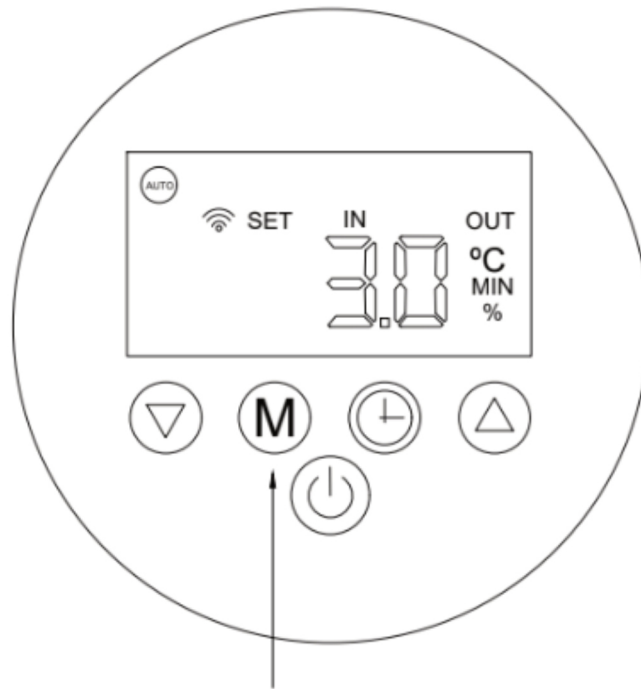

Step 8. Finishing the setup

- Place the Icetub Thermo cover on top. **Important:** If your Icetub is placed outside, it’s recommended to **screw in the Icetubs Thermo cover clips** into the wood to prevent it from being swept away by wind. The screws should go in the **middle of the board**. (See 8.1 Figure)
- **If you purchased the AquaFinesse Water Treatment All-in-One**, add the **weekly dosage** only **after** the Icetub has been filled. Then continue adding the weekly dosage every week. Dosage instructions can be found on support.icetubs.com.

8.1 Figure. Installing the IceBarrel’s Cover.

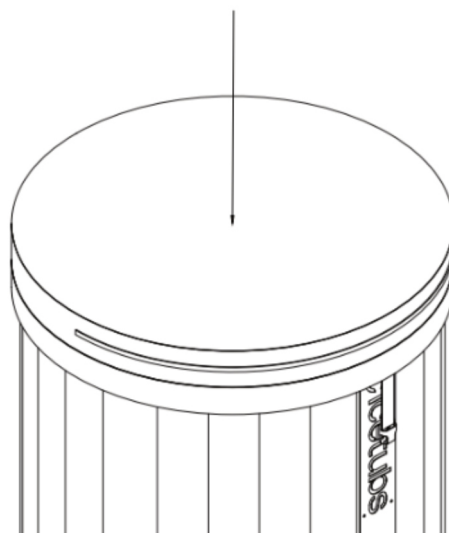

Step 9. Connecting Step Platforms

Prepare the stairs package. Make sure all the parts are there, and follow instructions below how to assemble it. (See Figures 9.1 - 9.7)

9.1 Figure. Stairs package components

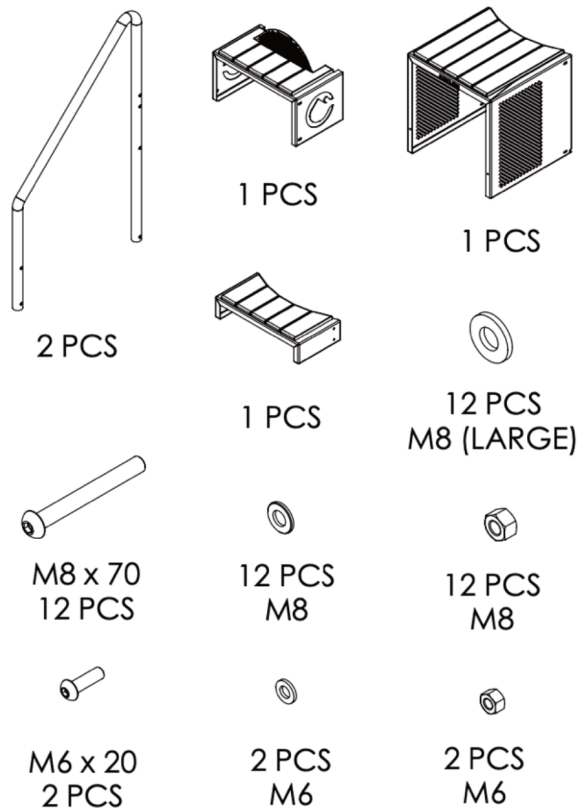

The delivery you have received includes all necessary components for assembly of the Stairs, except tooling.

Necessary Tooling (not Included):

- Wrench for bolts and nuts M6
- Wrench for bolts and nuts M8
- L-shaped hexagonal key for bolts M8

9.2 Figure. Connecting the stairs package's steps.

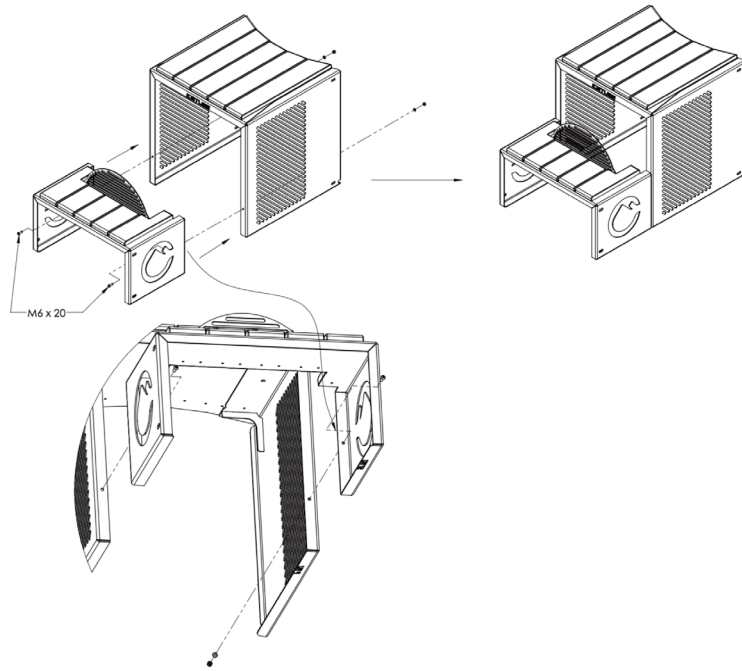

- Place the **1st lower step platform** in front of the **cooling engine protector (2nd step)**, ensuring they are parallel and the bolt holes are aligned (as shown in the 9.2 Figure).
- Insert one **M6 bolt** through each pair of aligned holes, placing a **washer** between the wall of the cooling engine protector and each nut.
- Secure each bolt with a nut. **Tighten securely.**

Note: There should be **no assembly parts between both steps.**

9.3 Figure. Connecting the stairs package's 1st rail onto the lower steps.

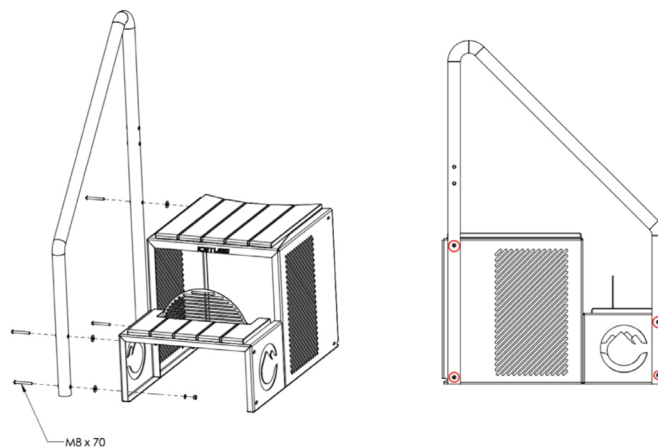

Attach one **handrail** to the previously connected step platforms from one side.

- Align the holes on the handrail tube with the pre-cut holes on the step platforms (see Figure 8.4).
- Insert one **M8 bolt through each hole (4 pcs total)**.
 - After the bolt passes through the handrail tube, add a **LARGE M8 washer**
 - Then move the bolt through the wall of the step. Add a **standard M8 washer** and then an **M8 nut**
- Secure each bolt with a nut. **Do not tighten completely yet.**

9.4 Figure. Connecting the stairs package's rails onto the upper step.

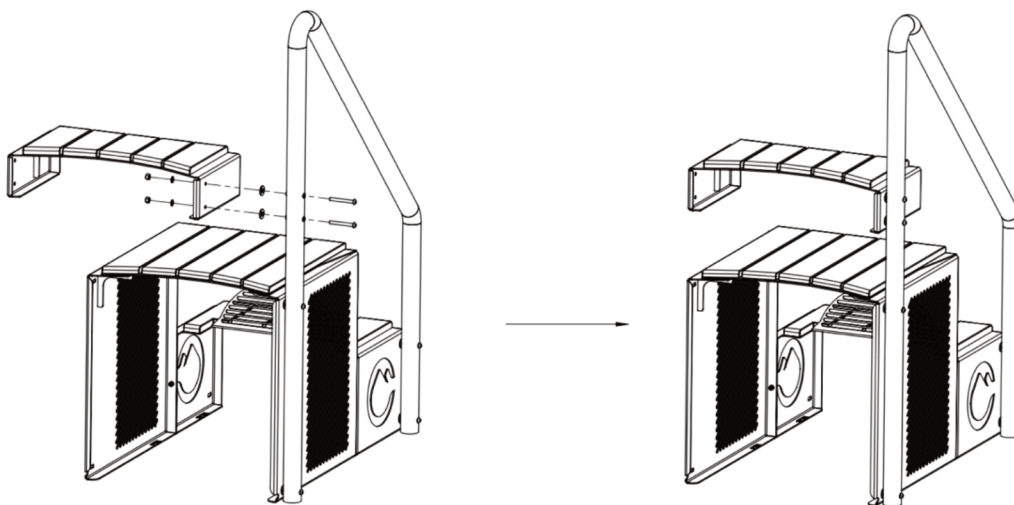

- Align the holes of the upper **3rd Step Platform** with the holes on the handrail.
- Insert **2x M8 bolts** following the same method as in Step 2:
 - Through the handrail → large washer → step wall → standard washer → M8 nut
- Secure bolts, but **do not tighten completely yet.**

9.5 Figure. Connecting the stairs package's 2nd rail onto the upper step.

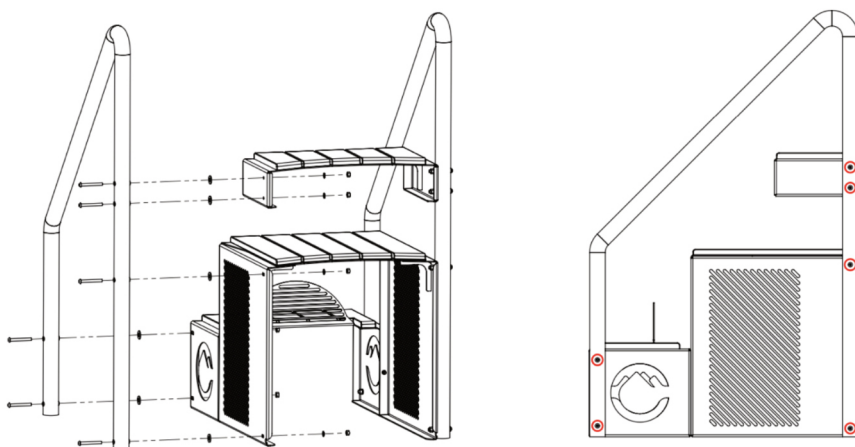

- Attach the second handrail to the assembly on the **opposite side**.
- Align the holes with the **pre-cut holes on all three step platforms**.
- Insert **6x M8** bolts using the same washer-nut configuration:
 - Large washer (before step wall)
 - Standard washer + nut (after step wall)
- Do not tighten completely yet.

Note: If holes do not align perfectly, you may need to slightly loosen bolts on the other side to adjust.

9.6 Figure. Finished construction of the stairs package.

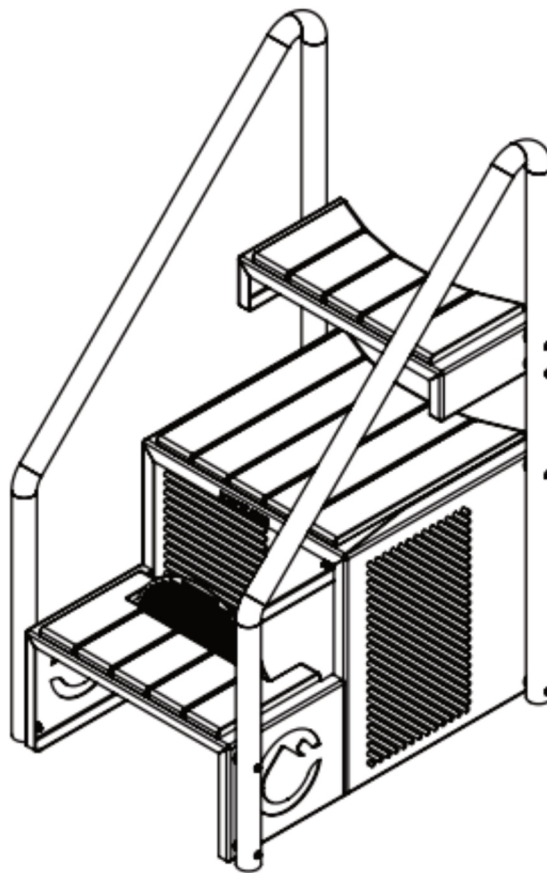

- Go back and **fully tighten all bolts** using the proper tools.
- Test the **stability** of the stairs and handrails.
- Adjust as needed to ensure everything is secure.

Note: The **top step should remain horizontally aligned** and must not shift when used.

- Once the stair has been assembled, position it over the engine and align it securely against the barrel.
- Take care during this step to prevent any damage to the wooden components.

9.7 Figure. Placement of the stairs package above the Cooling Engine.

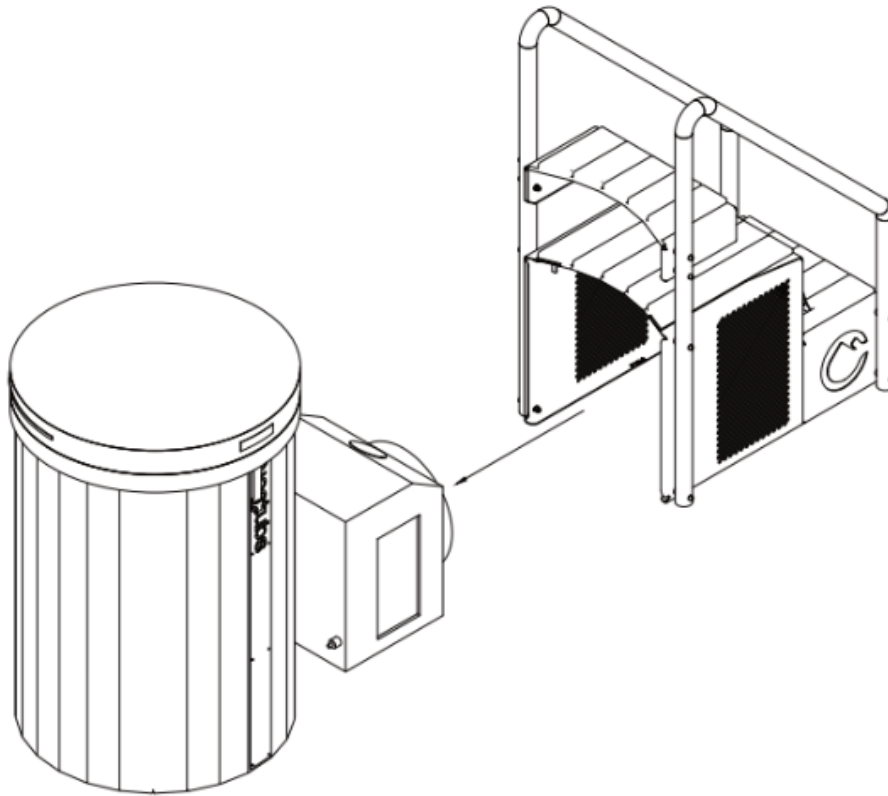

5.4 Setting up the IceBarrel XL

Step 1. Unpacking

- Remove the zip ties and take out the cardboard boxes and protective materials.
- Keep the engine standing for 24h before operation
- Immediately inspect for any damage. **If you notice anything, contact us at: service@icetubs.com**

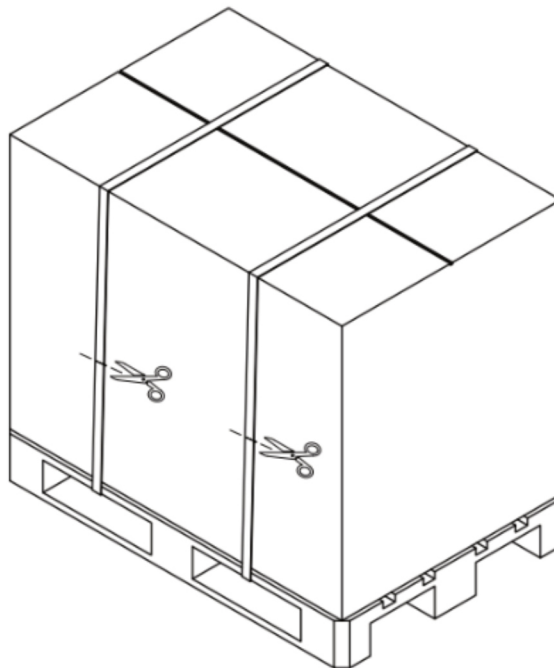

Step 2. Position the Components

- Place the barrel and cooling unit in their designated spots. (See 2.1 Figure)
Tip: Ensure the environment is well ventilated.
- **Weight:** A filled IceBarrel with one person = approx. **679 kg.**
 - Spread across 0,817 m² → **831 kg/m²** load.
- **Check load capacity:** Ensure the building structure can safely support this weight.

Cooling motor clearance:

- The cooling engine expels heat into the room, which needs to be regulated following the instructions mentioned in point '4. Conditions for Safe Usage.'
- It's important that when setting up the Icetub there is at least also **50 cm clearance** around the engine protector.

2.1 Figure. Positioning of IceBarrel XL & Cooling Engine.

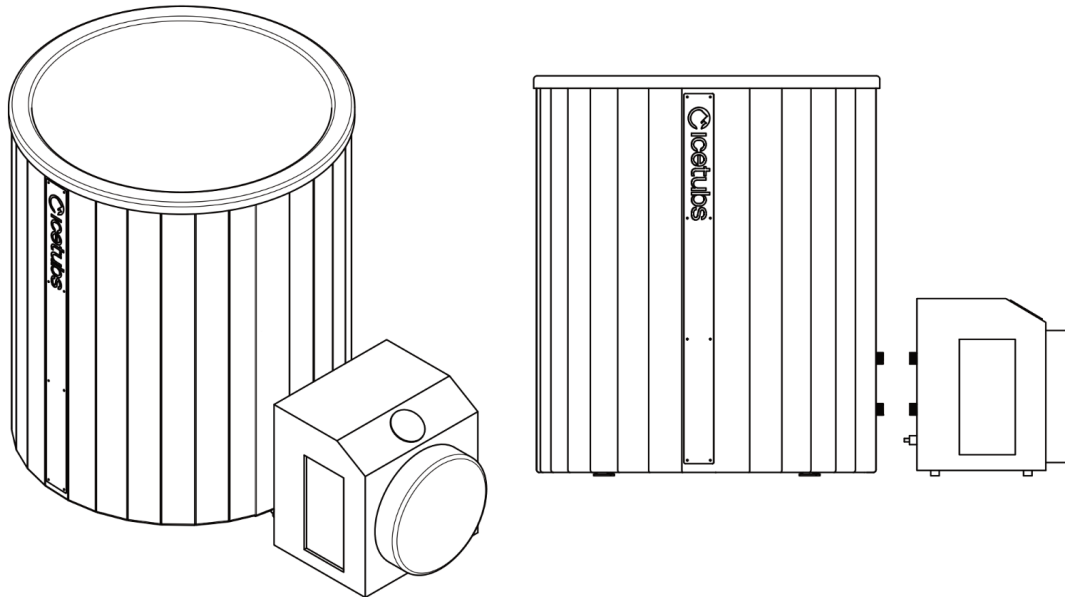

Step 3. Level the Tub and Cooling Unit

- Align the cooling unit's inlet and outlet with the connections on the Icetub, then adjust the leveling feet under both the Icetub and the cooling unit with a 16 mm wrench for Icetubs until they are perfectly aligned and stable.

Step 4. Attach the Engine connectors

- Attach the two engine connectors with rubber seals (to the lower inlet and top outlet of the water loop between the engine and the Icetub. (See 4.1 Figure) Please note that the rubber seals were provided with the engine connectors.
- Connect the other ends of the connectors, also with rubber rings in place, to the cooling unit.

Note: Do not turn on the cooling unit yet!

4.1 Figure. Engine Connectors' location.

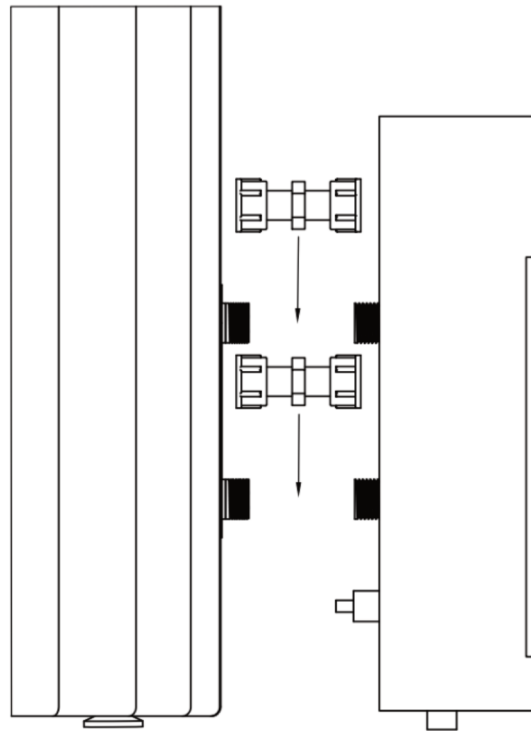

Step 5. Rinse the IceBarrel XL

- Remove the cap from the drain pipe, rinse the tub thoroughly, and drain the water completely. (See Figure 5.1)
- (Optional but recommended) Install the **drain attachment** provided together with the Icetubs for easier draining in the future. Make sure it's not left open before filling up the IceBarrel. (See Figure 5.2)
- If drain attachment is not installed, reinstall the cap of the drain pipe.

5.1 Figure. Rinsing the IceBarrel XL

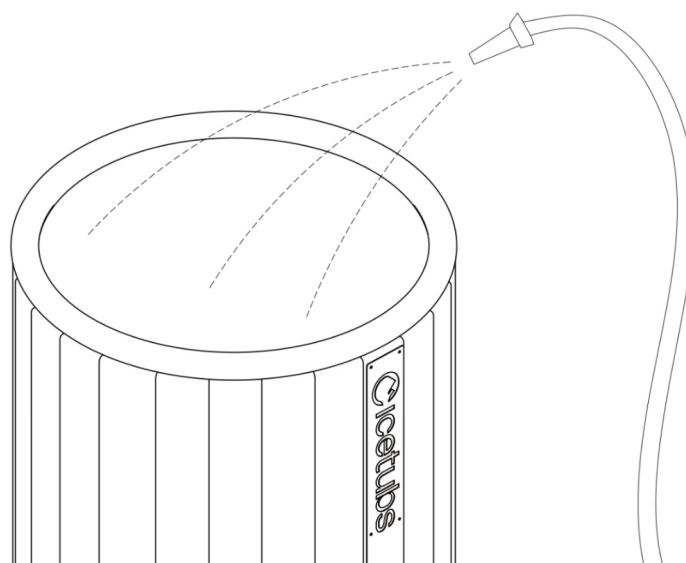

5.2 Figure. Gardena Drain Hose Attachment.

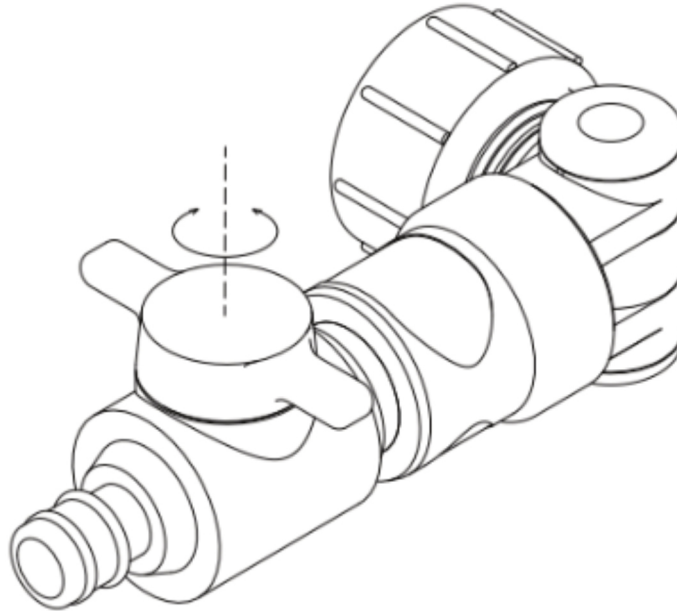

Step 6. Prepare the IceBarrel XL

- Once the water level reaches the **top outlet of the water** loop between the cooling unit and the Icetub, flush out any air from the system:
 - Hold your **garden hose** against the **top outlet and then bottom inlet** separately to push out air.
 - Fully **submerge the filter** under water in the Icetub to release all trapped air.
 - Screw the filter onto the **bottom connection (inlet) of the water loop inside the Icetub**. This prevents debris from entering the system and ensures smooth operation. (See 6.1 Figure)

Important note: Never use Icetubs without a filter installed, as this will result in engine failure over time and voids warranty!
- Install the metal seat, that goes above the filter. (See 6.2 Figure)
- Check that all connectors are watertight and not dripping water. Tighten further if necessary. (See 6.3 Figure)
- Fill the Icetub with water up to **20 cm from the rim**, considering your body weight and height. (See 6.4 Figure)

6.1 Figure. Installing the Filter on the lower inlet in the IceBarrel XL.

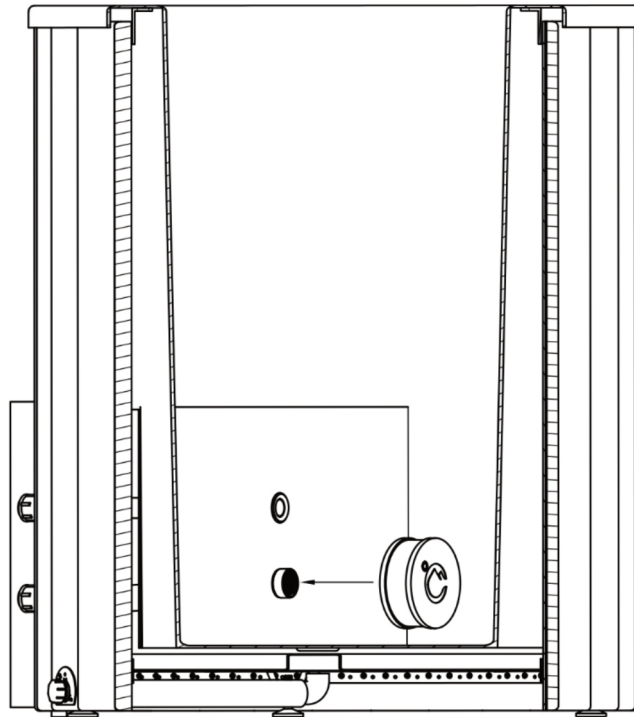

6.3 Figure. Leakage checking.

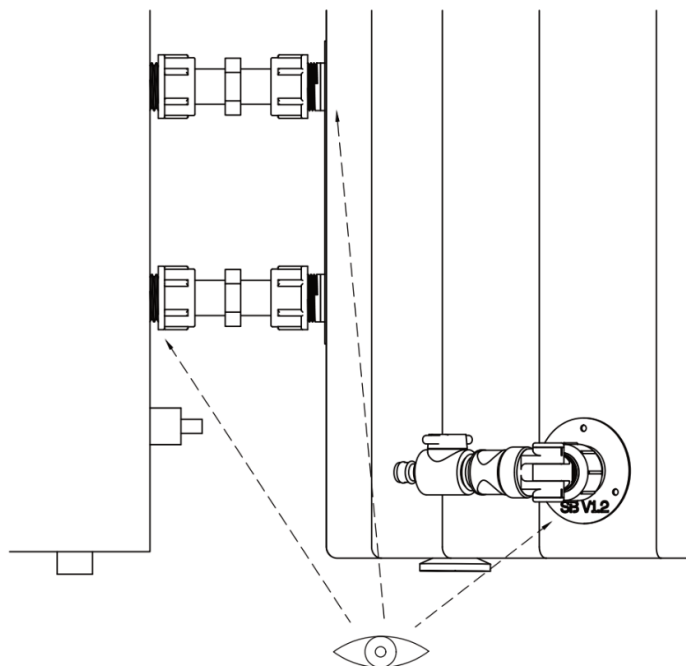

6.4 Figure. Filled IceBarrel XL.

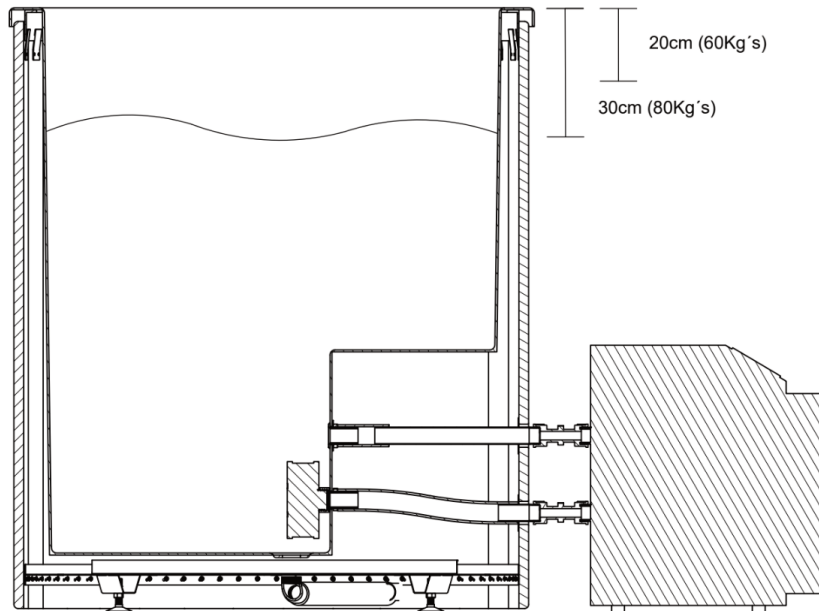

Step 7. Prepare the Engine

- Plug the cooling unit into a grounded outlet. Ensure the small box that's on the cable (**circuit breaker**) is **hanging against the wall** and not lying on the ground.
Important: The power cable and the circuit breaker is **water-resistant, not waterproof**, if your setup is outdoors, you must ensure that is **protected from rain and direct moisture**. (See 7.1 Figure)
- Press the **“ON”** button to turn on the cooling unit. Confirm that the circuit breaker is in the **ON** position. (See 7.2 Figure)
- Set the engine Automatic mode by pressing the **“M”** button until the **‘AUTO’** mode appears. (Automatic mode is able to cool and heat the water at the same time) (See 7.3 Figure)
- Set your desired temperature using the **“↑”** and **“↓”** buttons.
- Use the Icetubs app to adjust the settings remotely (ensure the cooling unit is close to your router for a stable connection):
 - Download the application in **Google Play Store or App Store**
 - Follow the instructions in the app to connect your Icetubs engine and control it remotely.
- It's recommended to read the tips & tricks in the app on how to adjust your Icetubs usage routine to progress efficiently.

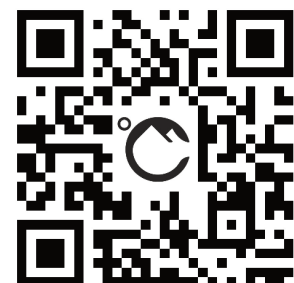

7.1 Figure. Electrical Outlet with grounding pins schematic.

Type F Socket

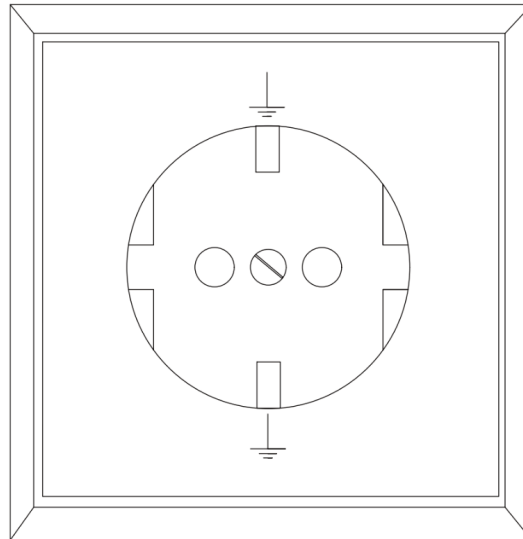

7.2 Figure. Cooling Engine's Control Panel. "ON" button highlighted.

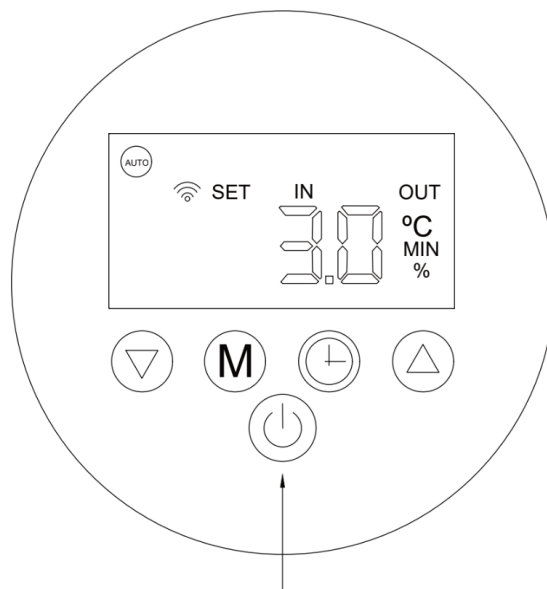

7.3 Figure. Cooling Engine's Control Panel. "M" button highlighted.

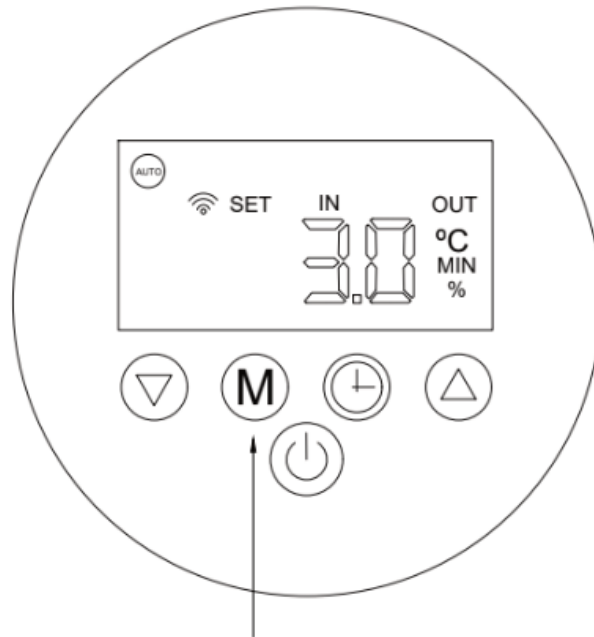

Step 8. Finishing the setup

- Place the Icetub Thermo cover on top. **Important:** If your Icetub is placed outside, it's recommended to **screw in the Icetubs Thermo cover clips** into the wood to prevent it from being swept away by wind. The screws should go in the **middle of the board**. (See 8.1 Figure & 8.2 Figure)
- **If you purchased the AquaFinesse Water Treatment All-in-One**, add the **weekly dosage** only **after** the Icetub has been filled. Then continue adding the weekly dosage every week. Dosage instructions can be found on support.icetubs.com.

8.1 Figure. Installing the Cover.

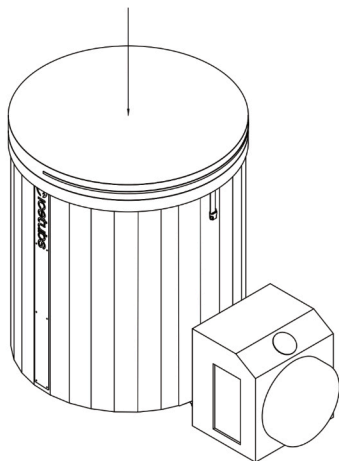

8.2 Figure. Cooling Engine's Protector

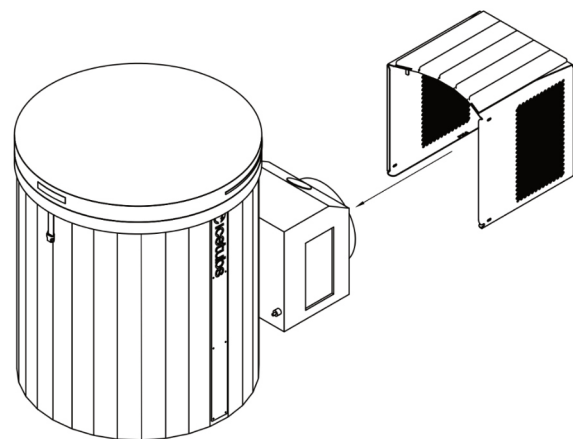

5.5 Setting Up the IceBarrel XL with Stairs

Step 1. Unpacking

- Remove the zip ties and take out the cardboard boxes and protective materials.
- Keep the engine standing for 24h before operation
- Immediately inspect for any damage. **If you notice anything, contact us at: service@icetubs.com**

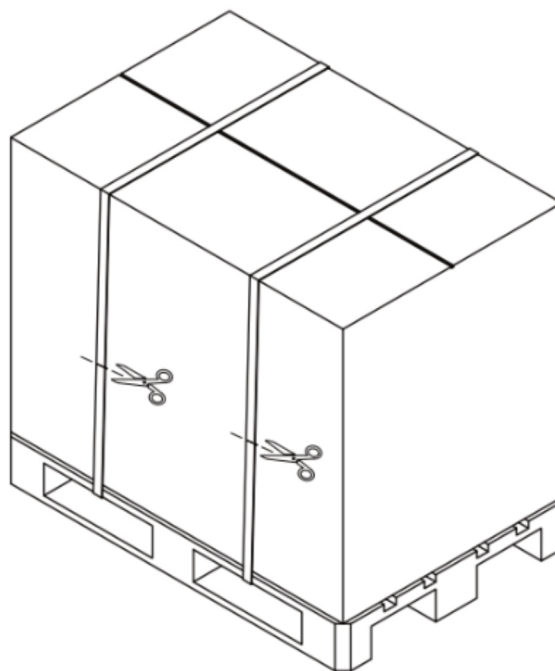

Step 2. Position the Components

- Place the barrel and cooling unit in their designated spots. (See 2.1 Figure)
Tip: Ensure the environment is well ventilated.
- **Weight:** A filled IceBarrel with one person = approx. **703 kg.**
 - Spread across 0,817 m² → **860 kg/m²** load.
- **Check load capacity:** Ensure the building structure can safely support this weight.

Cooling motor clearance:

- The cooling engine expels heat into the room, which needs to be regulated following the instructions mentioned in point '4. Conditions for Safe Usage.'
- It's important that when setting up the Icetub there is at least also **50 cm clearance** around the engine protector.

2.1 Figure. Positioning of IceBarrel XL & Cooling Engine.

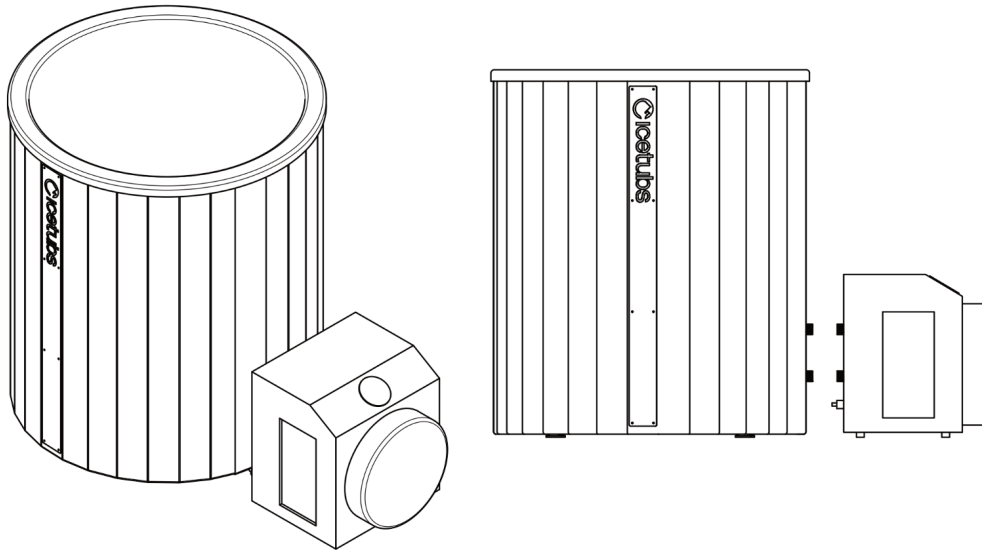

Step 3. Level the Tub and Cooling Unit

- Align the cooling unit's inlet and outlet with the connections on the Icetub, then adjust the leveling feet under both the Icetub and the cooling unit with a **16 mm** wrench for Icetubs until they are perfectly aligned and stable.

Step 4. Attach the Engine connectors

- Attach the two engine connectors with rubber seals (to the lower inlet and top outlet of the water loop between the engine and the Icetub. (See 4.1 Figure) Please note that the rubber seals were provided with the engine connectors.
 - Connect the other ends of the connectors, also with rubber rings in place, to the cooling unit.
- Note:** Do not turn on the cooling unit yet!

4.1 Figure. Engine Connectors' location.

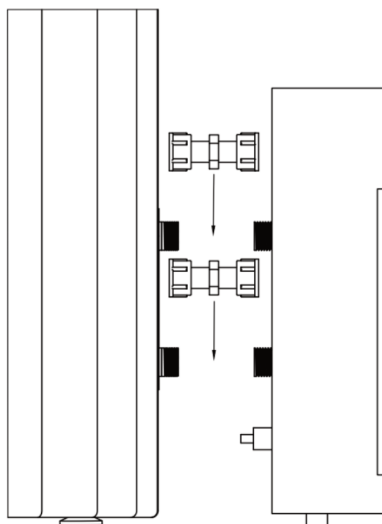

Step 5. Rinse the IceBarrel XL

- Remove the cap from the drain pipe, rinse the tub thoroughly, and drain the water completely. (See Figure 5.1)
- (Optional but recommended) Install the **drain attachment** provided together with the Icetubs for easier draining in the future. Make sure it's not left open before filling up the IceBarrel.(See Figure 5.2)
- If drain attachment is not installed, reinstall the cap of the drain pipe.

5.1 Figure. Rinsing the IceBarrel XL

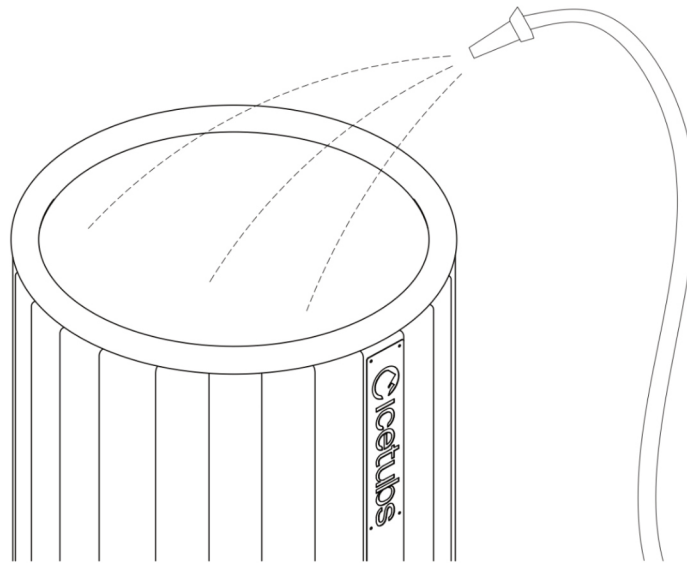

5.2 Figure. Gardena Drain Hose Attachment.

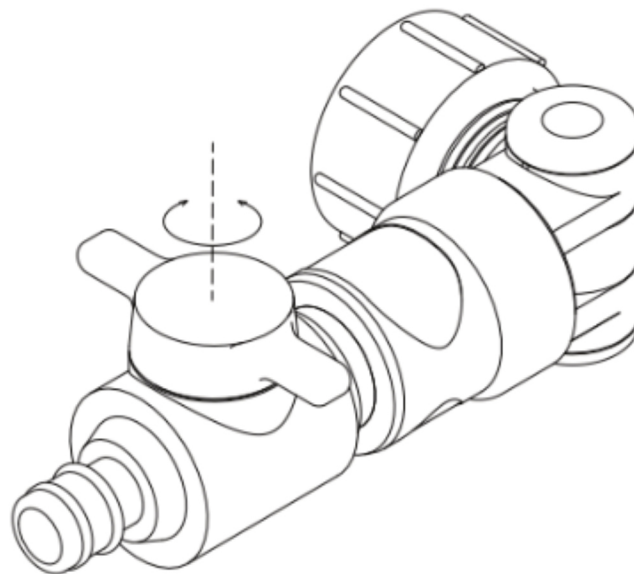

Step 6. Prepare the IceBarrel XL

- Once the water level reaches the **top outlet of the water** loop between the cooling unit and the Icetub, flush out any air from the system:
 - Hold your **garden hose** against the **top outlet and then bottom inlet** separately to push out air.
 - Fully **submerge the filter** under water in the Icetub to release all trapped air.
 - Screw the filter onto the **bottom connection (inlet) of the water loop inside the Icetub**. This prevents debris from entering the system and ensures smooth operation. (See 6.1 Figure)

Important note: Never use Icetubs without a filter installed, as this will result in engine failure over time and voids warranty!

- Install the metal seat, that goes above the filter. (See 6.2 Figure)
- Check that all connectors are watertight and not dripping water. Tighten further if necessary. (See 6.3 Figure)
- Fill the Icetub with water up to **20 cm from the rim**, considering your body weight and height. (See 6.4 Figure)

6.1 Figure. Installing the Filter on the lower inlet in the IceBarrel XL.

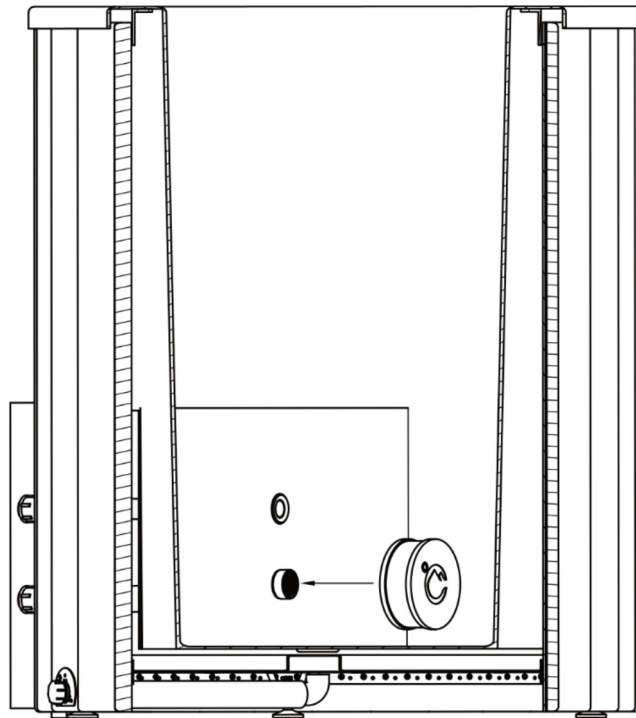

6.3 Figure. Leakage checking.

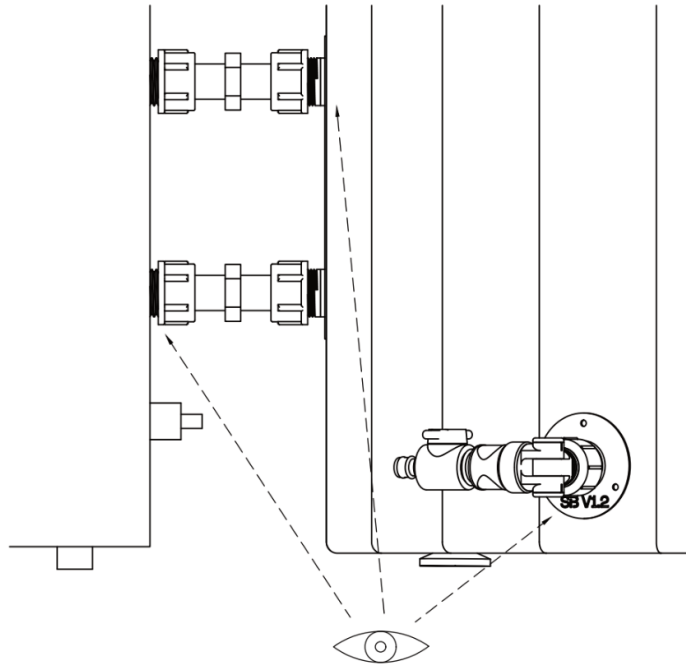

6.4 Figure. Filled IceBarrel XL.

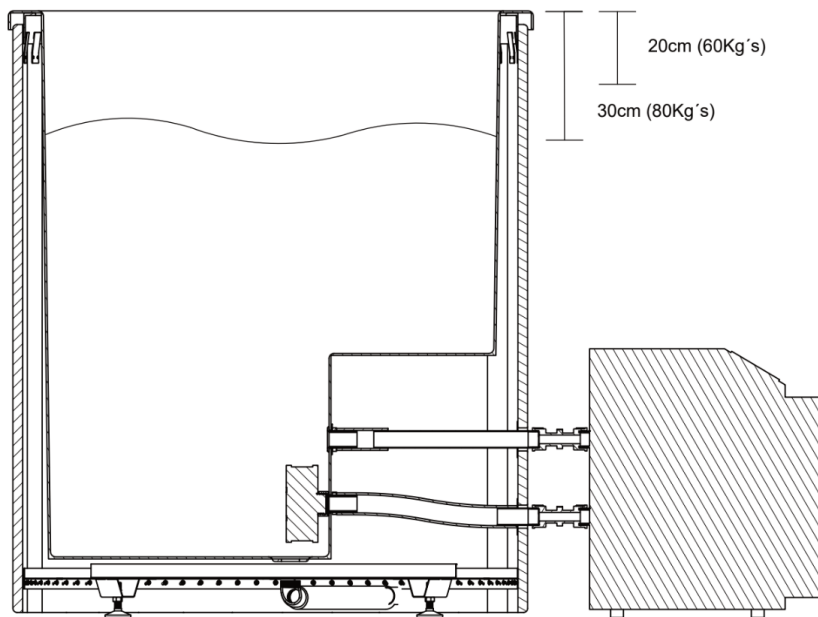

Step 7. Prepare the Engine

- Plug the cooling unit into a grounded outlet. Ensure the small box that's on the cable (**circuit breaker**) is **hanging against the wall** and not lying on the ground.
Important: The power cable and the circuit breaker is **water-resistant, not waterproof**, if your setup is outdoors, you must ensure that is **protected from rain and direct moisture**. (See 7.1 Figure)
- Press the **“ON”** button to turn on the cooling unit. Confirm that the circuit breaker is in the **ON** position. (See 7.2 Figure)
- Set the engine Automatic mode by pressing the **“M”** button until the **‘AUTO’** mode appears. (Automatic mode is able to cool and heat the water at the same time) (See 7.3 Figure)
- Set your desired temperature using the **“↑”** and **“↓”** buttons.
- Use the Icetubs app to adjust the settings remotely (ensure the cooling unit is close to your router for a stable connection):
 - Download the application in **Google Play Store or App Store**
 - Follow the instructions in the app to connect your Icetubs engine and control it remotely.
- It's recommended to read the tips & tricks in the app on how to adjust your Icetubs usage routine to progress efficiently.

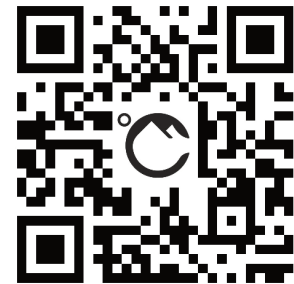

7.1 Figure. Electrical Outlet with grounding pins schematic.

Type F Socket

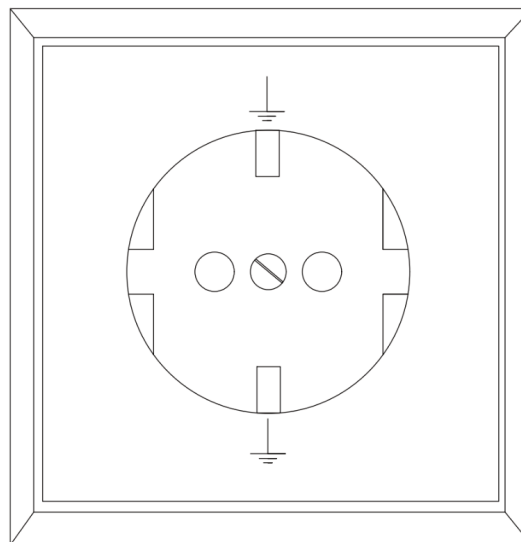

7.2 Figure. Cooling Engine's Control Panel. "ON" button highlighted.

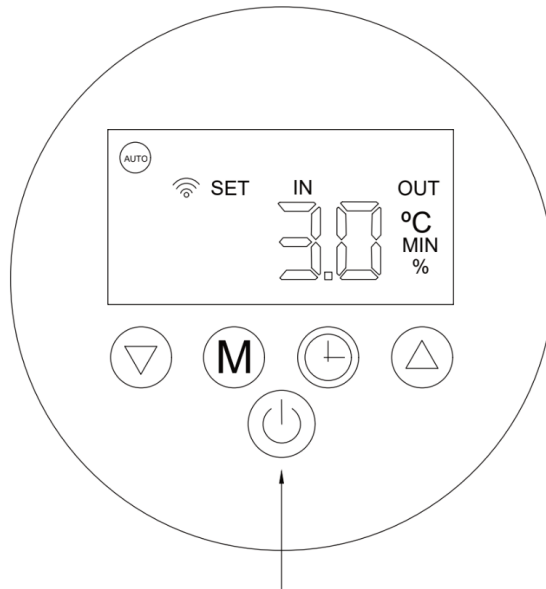

7.3 Figure. Cooling Engine's Control Panel. "M" button highlighted.

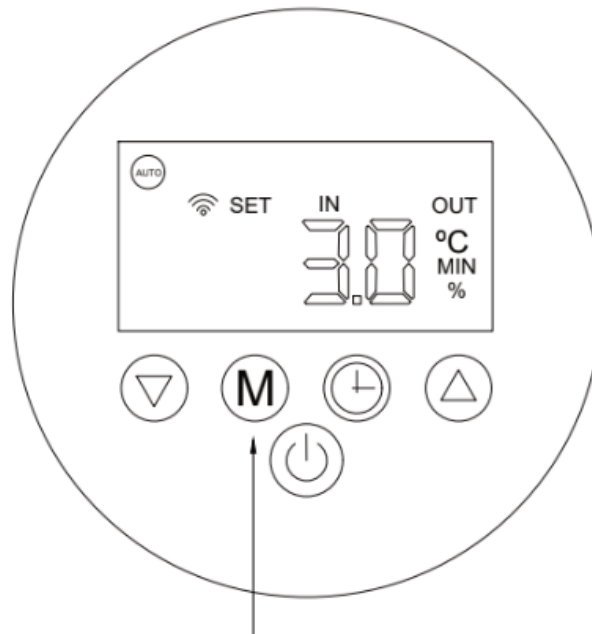

Step 8. Finishing the setup

- Place the Icetub Thermo cover on top. **Important:** If your Icetub is placed outside, it's recommended to **screw in the Icetubs Thermo cover clips** into the wood to prevent it from being swept away by wind. The screws should go in the **middle of the board**. (See 8.1 Figure & 8.2 Figure)
- **If you purchased the AquaFinesse Water Treatment All-in-One**, add the **weekly dosage** only **after** the Icetub has been filled. Then continue adding the weekly dosage every week. Dosage instructions can be found on support.icetubs.com.

8.1 Figure. Installing the IceBarrel's XL Cover.

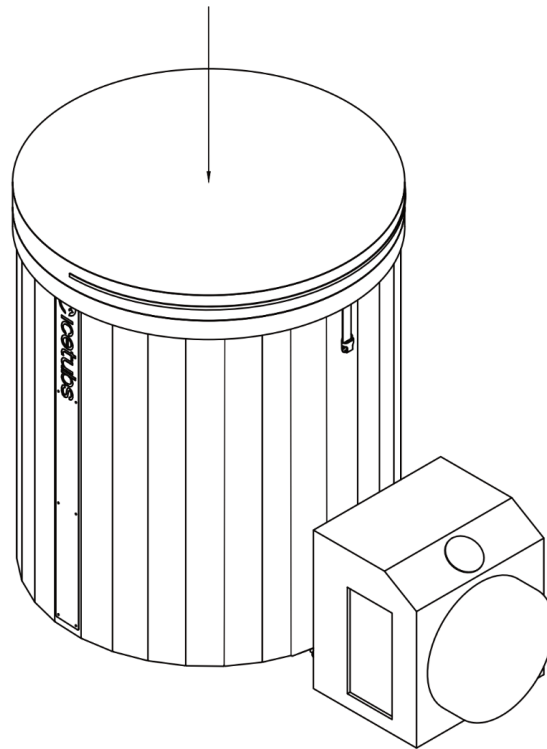

Step 9. Connecting Step Platforms

Prepare the stairs package. Make sure all the parts are there, and follow instructions below how to assemble it. (See Figures 9.1 - 9.7)

9.1 Figure. Stairs package components

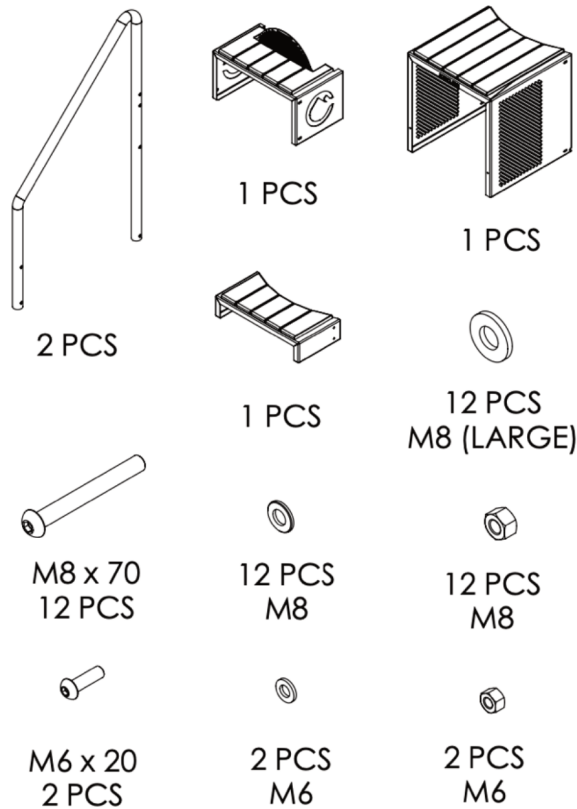

The delivery you have received includes all necessary components for assembly of the **Stairs**, except tooling.

Necessary Tooling (not Included):

- Wrench for bolts and nuts M6
- Wrench for bolts and nuts M8
- L-shaped hexagonal key for bolts M8

9.2 Figure. Connecting the stairs package's steps.

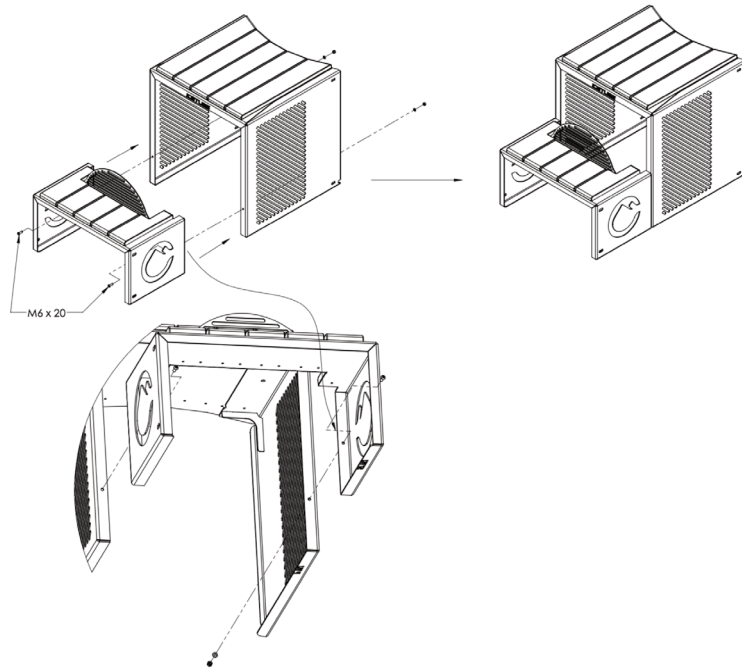

- Place the **1st lower step platform** in front of the **cooling engine protector (2nd step)**, ensuring they are parallel and the bolt holes are aligned (as shown in the 9.2 Figure).
- Insert one **M6 bolt** through each pair of aligned holes, placing a **washer** between the wall of the cooling engine protector and each nut.
- Secure each bolt with a nut. **Tighten securely.**

Note: There should be **no assembly parts between both steps.**

9.3 Figure. Connecting the stairs package's 1st rail onto the lower steps.

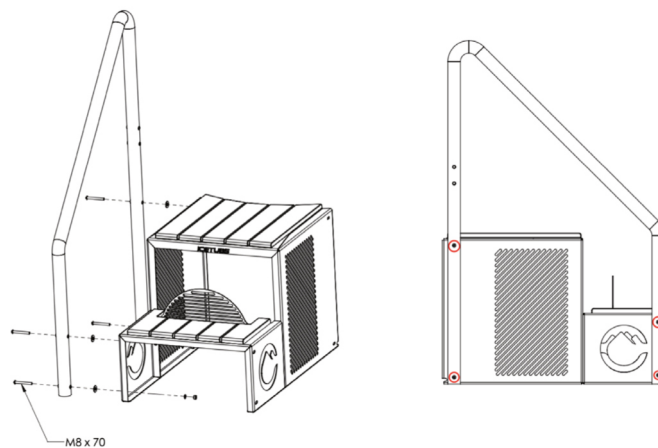

Attach one **handrail** to the previously connected step platforms from one side.

- Align the holes on the handrail tube with the pre-cut holes on the step platforms (see Figure 8.4).
- Insert one **M8 bolt through each hole (4 pcs total)**.
 - After the bolt passes through the handrail tube, add a **LARGE M8 washer**
 - Then move the bolt through the wall of the step Add a **standard M8 washer** and then an **M8 nut**
- Secure each bolt with a nut. **Do not tighten completely yet.**

9.4 Figure. Connecting the stairs package's rails onto the upper step.

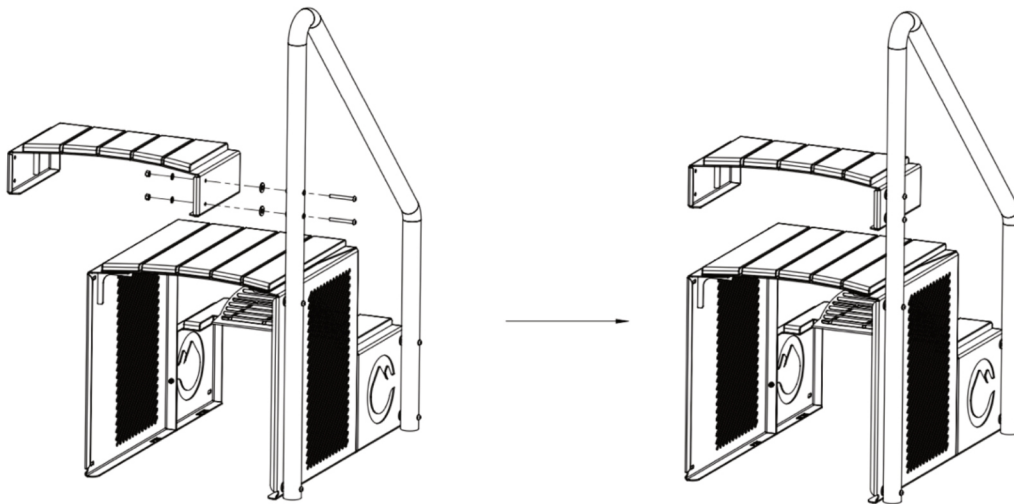

- Align the holes of the upper **3rd Step Platform** with the holes on the handrail.
- Insert **2x M8 bolts** following the same method as in Step 2:
 - Through the handrail → large washer → step wall → standard washer → M8 nut
- Secure bolts, but **do not tighten completely yet.**

9.5 Figure. Connecting the stairs package's 2nd rail onto the upper step.

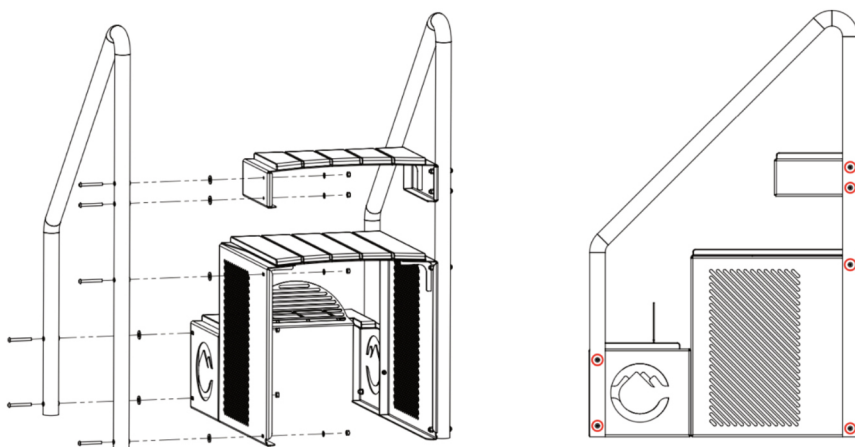

- Attach the second handrail to the assembly on the **opposite side**.
- Align the holes with the **pre-cut holes on all three step platforms**.
- Insert **6x M8** bolts using the same washer-nut configuration:
 - Large washer (before step wall)
 - Standard washer + nut (after step wall)
- Do not tighten completely yet.

Note: If holes do not align perfectly, you may need to slightly loosen bolts on the other side to adjust.

9.6 Figure. Finished construction of the stairs package.

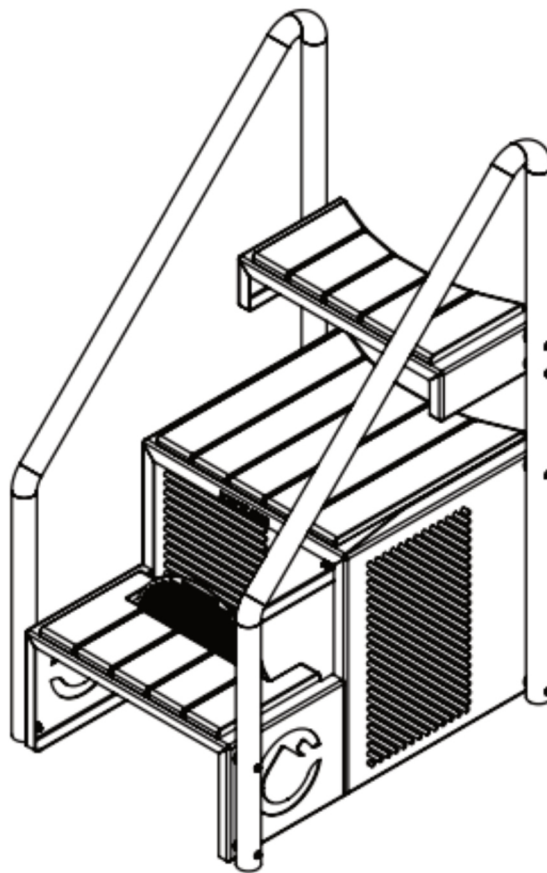

- Go back and **fully tighten all bolts** using the proper tools.
- Test the **stability** of the stairs and handrails.
- Adjust as needed to ensure everything is secure.

Note: The **top step should remain horizontally aligned** and must not shift when used.

- Once the stair has been assembled, position it over the engine and align it securely against the barrel.
- Take care during this step to prevent any damage to the wooden components.

9.7 Figure. Placement of the stairs package above the Cooling Engine.

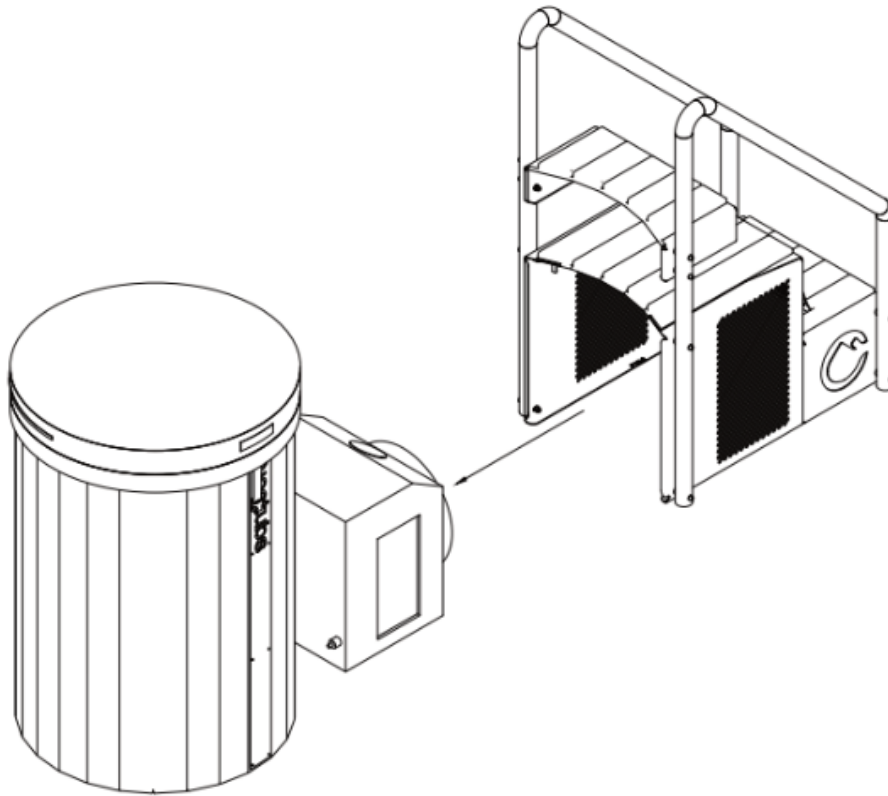

5.6 Setting up the IceBath

Step 1. Unpacking

- Remove the zip ties and take out the cardboard boxes and protective materials.
- Keep the engine standing for 24h before operation
- Immediately inspect for any damage. **If you notice anything, contact us at: service@icetubs.com**

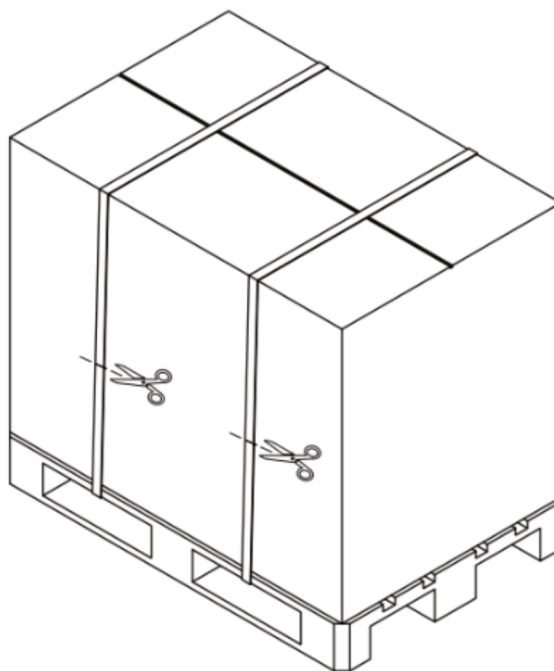

Step 2. Position the Components

- Place the barrel and cooling unit in their designated spots. (See 2.1 Figure)
Tip: Ensure the environment is well ventilated.
- **Weight:** A filled IceBarrel with one person = approx. **635 kg.**
 - Spread across 1,576 m² → **403 kg/m²** load.
- **Check load capacity:** Ensure the building structure can safely support this weight.

Cooling motor clearance:

- The cooling engine expels heat into the room, which needs to be regulated following the instructions mentioned in point '4. Conditions for Safe Usage.'
- It's important that when setting up the Icetub there is at least also **50 cm clearance** around the engine protector.

2.1 Figure. Positioning of IceBath & Cooling Engine.

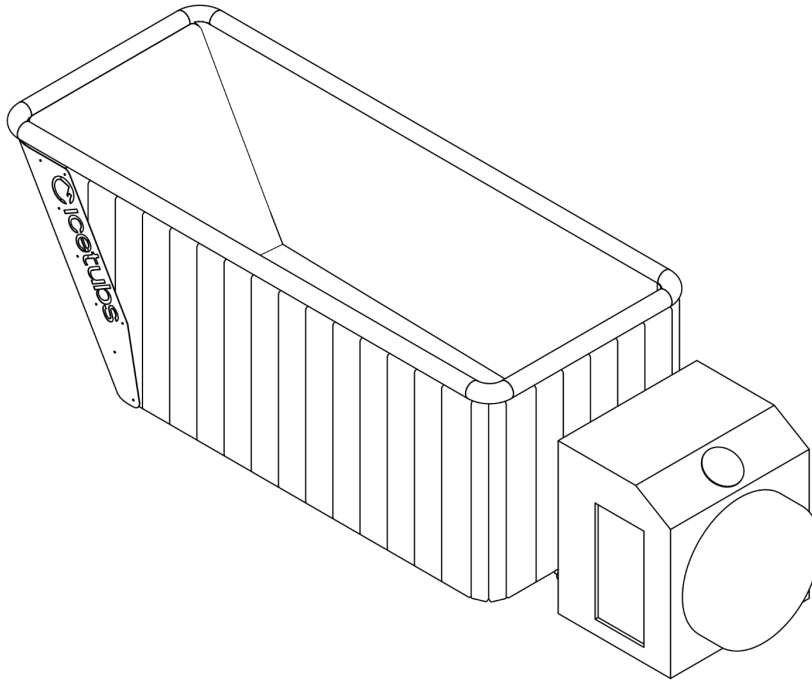

Step 3. Level the Tub and Cooling Unit

- Align the cooling unit's inlet and outlet with the connections on the Icetub, then adjust the leveling feet under both the Icetub and the cooling unit with a **16 mm** wrench for Icetubs until they are perfectly aligned and stable.

Step 4. Attach the Engine connectors

- Attach the two engine connectors with rubber seals to the lower inlet and top outlet of the water loop between the engine and the Icetub (See 4.1 Figure). Please note that the rubber seals were provided with the engine connectors.
- Connect the other ends of the connectors, also with rubber rings in place, to the cooling unit.

Note: Do not turn on the cooling unit yet!

4.1 Figure. Engine Connectors' location.

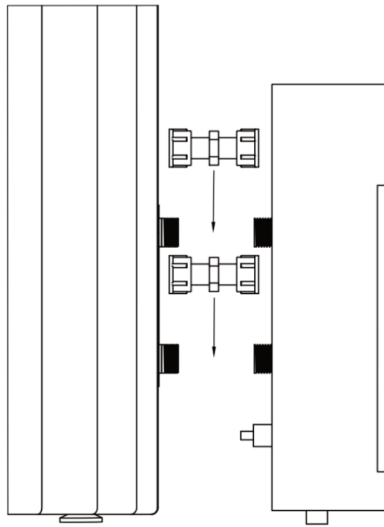

Step 5. Rinse the IceBarrel XL

- Remove the cap from the drain pipe, rinse the tub thoroughly, and drain the water completely. (See Figure 5.1)
- (Optional but recommended) Install the **drain attachment** provided together with the Icetubs for easier draining in the future. Make sure it's not left open before filling up the IceBarrel.(See Figure 5.2)
- If drain attachment is not installed, reinstall the cap of the drain pipe.

5.1 Figure. Rinsing the IceBath.

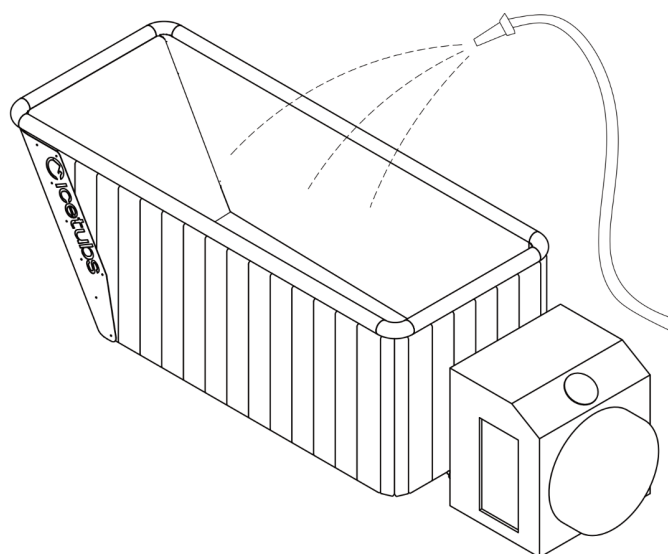

5.2 Figure. Gardena Drain Hose Attachment.

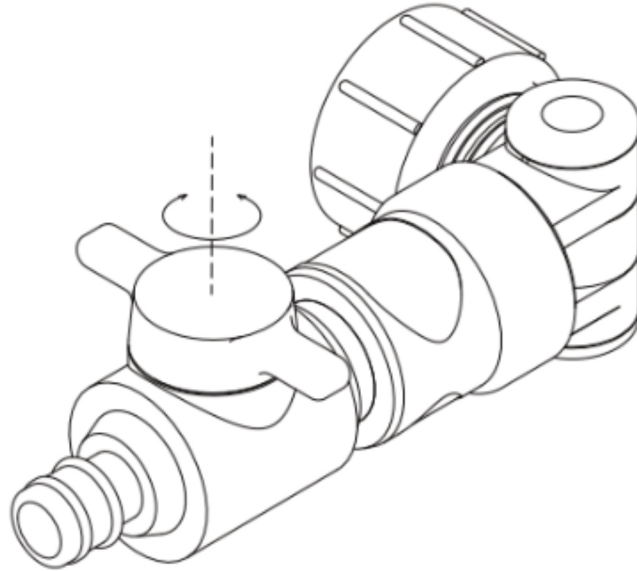

Step 6. Prepare the IceBath

- Once the water level reaches the **top outlet of the water** loop between the cooling unit and the Icetub, flush out any air from the system:
 - Hold your **garden hose** against the **top outlet and then bottom inlet** separately to push out air.
 - Fully **submerge the filter** under water in the Icetub to release all trapped air.
 - Screw the filter onto the **bottom connection (inlet) of the water loop inside the Icetub**. This prevents debris from entering the system and ensures smooth operation. (See 6.1 Figure)

Important note: Never use Icetubs without a filter installed, as this will result in engine failure over time and voids warranty!
- Install the metal seat, that goes above the filter. (See 6.2 Figure)
- Check that all connectors are watertight and not dripping water. Tighten further if necessary. (See 6.3 Figure)
- Fill the Icetub with water up to **20 cm from the rim**, considering your body weight and height. (See 6.4 Figure)

6.1 Figure. Installing the Filter on the lower inlet in the IceBath.

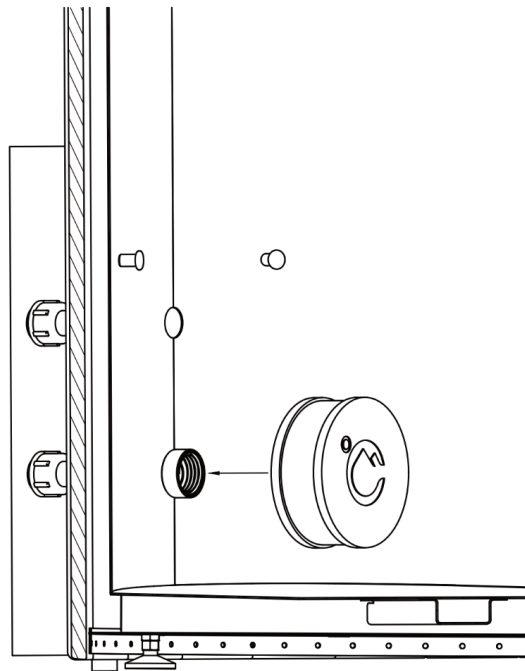

6.2 Figure. Leakage checking.

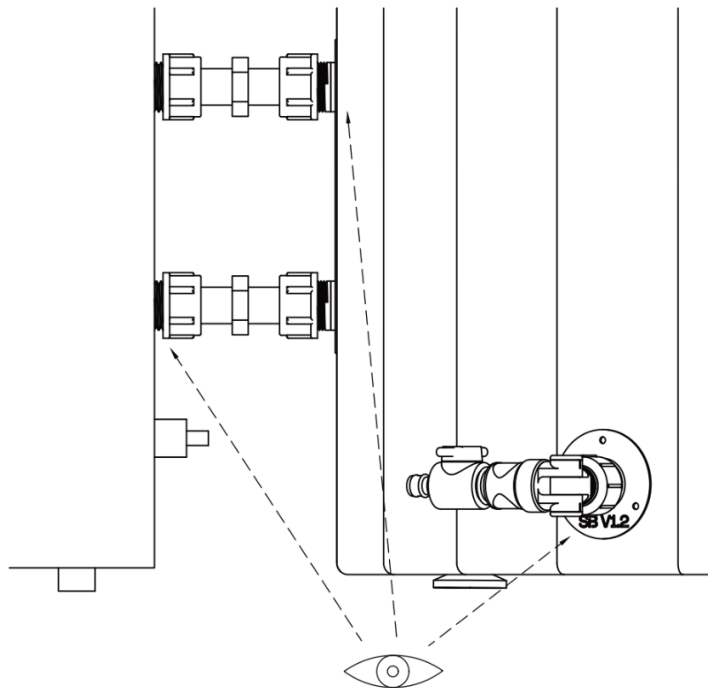

6.1 Figure. Filled IceBath.

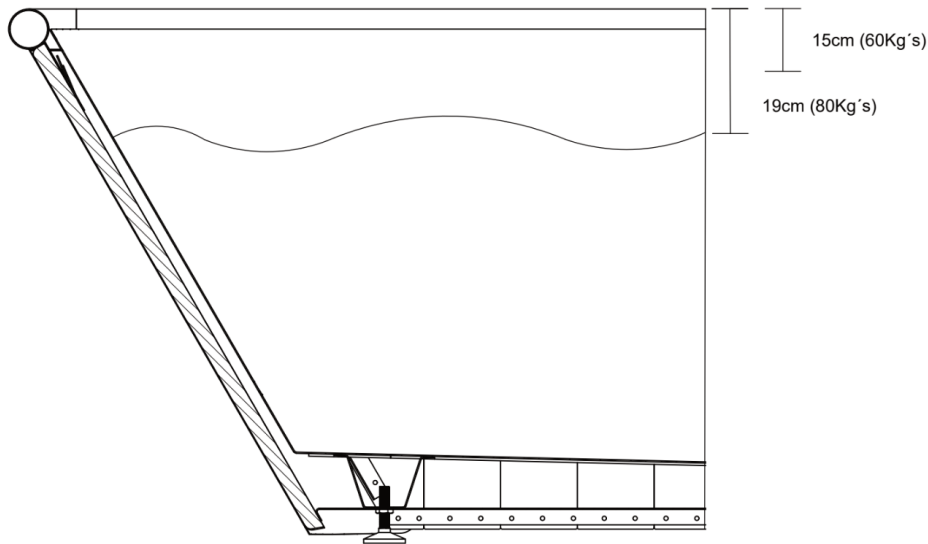

Step 7. Prepare the Engine

- Plug the cooling unit into a grounded outlet. Ensure the small box that's on the cable (**circuit breaker**) is **hanging against the wall** and not lying on the ground.
Important: The power cable and the circuit breaker is **water-resistant, not waterproof**, if your setup is outdoors, you must ensure that is **protected from rain and direct moisture**. (See 7.1 Figure)
- Press the “**ON**” button to turn on the cooling unit. Confirm that the circuit breaker is in the **ON** position. (See 7.2 Figure)
- Set the engine Automatic mode by pressing the “**M**” button until the ‘**AUTO**’ mode appears. (Automatic mode is able to cool and heat the water at the same time) (See 7.3 Figure)
- Set your desired temperature using the “↑” and “↓” buttons.
- Use the Icetubs app to adjust the settings remotely (ensure the cooling unit is close to your router for a stable connection):
 - Download the application in **Google Play Store or App Store**
 - Follow the instructions in the app to connect your Icetubs engine and control it remotely.
- It's recommended to read the tips & tricks in the app on how to adjust your Icetubs usage routine to progress efficiently.

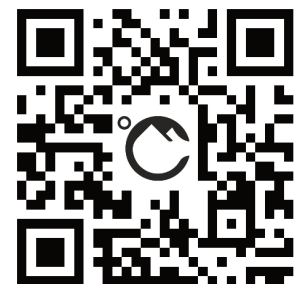

7.1 Figure. Electrical Outlet with grounding pins schematic.

Type F Socket

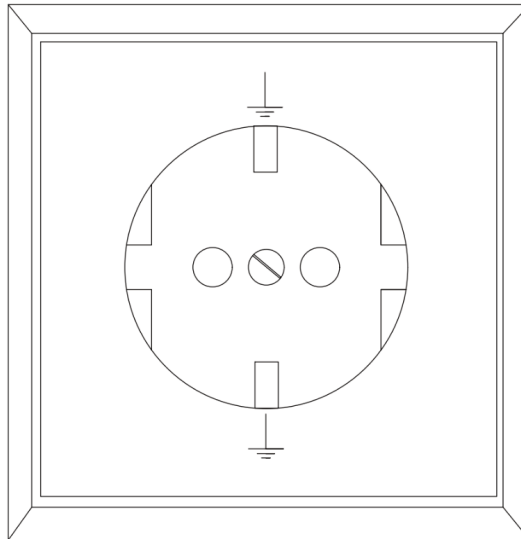

7.2 Figure. Cooling Engine's Control Panel. "ON" button highlighted.

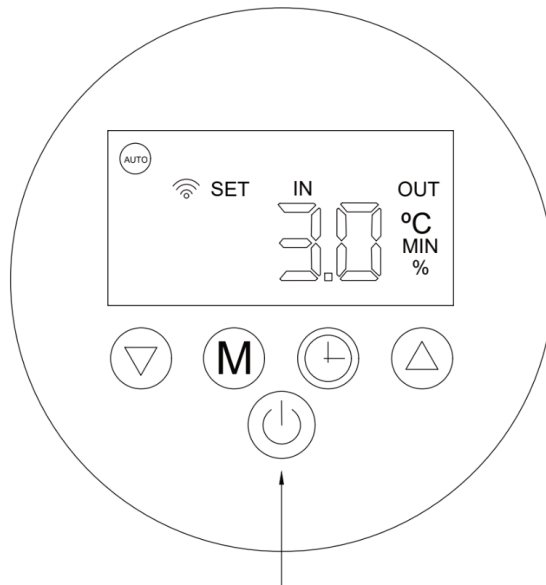

7.3 Figure. Cooling Engine's Control Panel. "M" button highlighted.

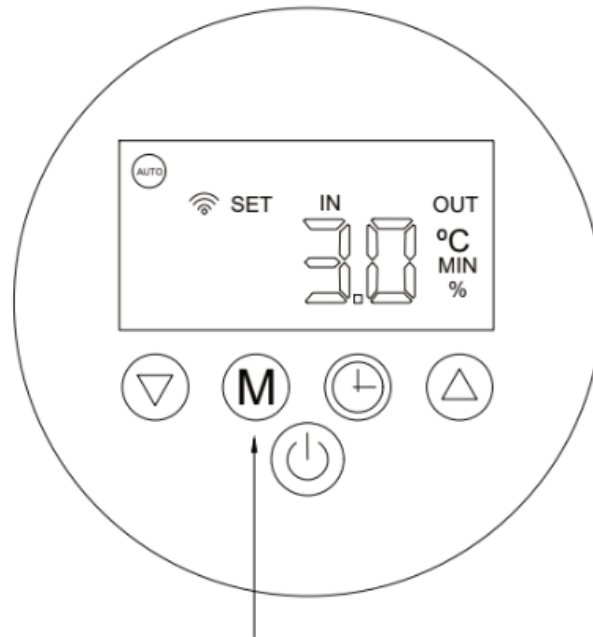

Step 8. Finishing the setup

- Place the Icetub Thermo cover on top. **Important:** If your Icetub is placed outside, it's recommended to **screw in the Icetubs Thermo cover clips** into the wood to prevent it from being swept away by wind. The screws should go in the **middle of the board**. (See 8.1 Figure & 8.2 Figure)
- **If you purchased the AquaFinesse Water Treatment All-in-One**, add the **weekly dosage** only **after** the Icetub has been filled. Then continue adding the weekly dosage every week. Dosage instructions can be found on support.icetubs.com.

8.1 Figure. Installing the IceBath's Cover.

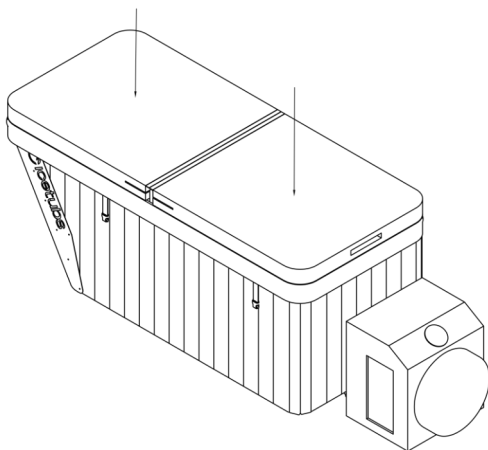

8.2 Figure. Cooling Engine's Protector.

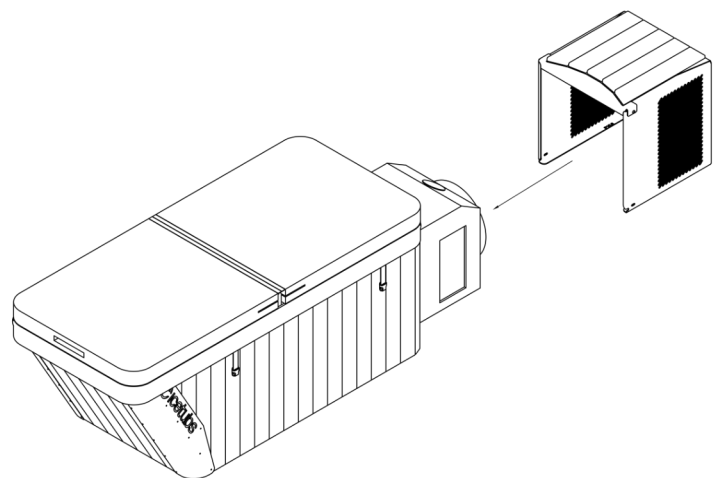

5.7 Setting up the IceBath XL

Step 1. Unpacking

- Remove the zip ties and take out the cardboard boxes and protective materials.
- Keep the engine standing for 24h before operation
- Immediately inspect for any damage. **If you notice anything, contact us at: service@icetubs.com**

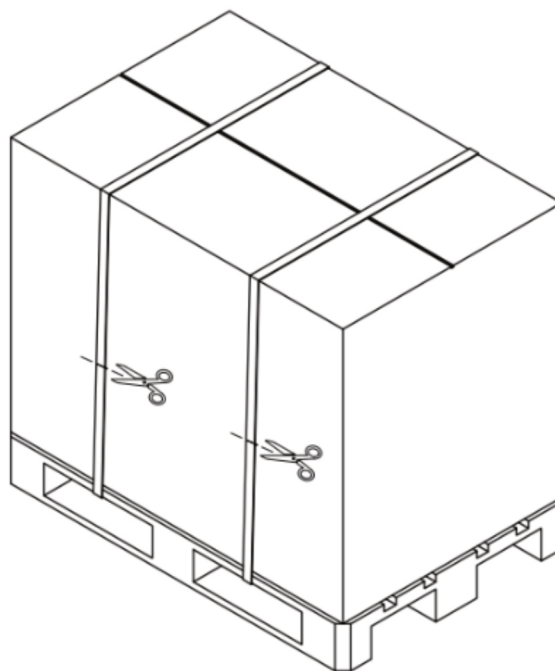

Step 2. Position the Components

- Place the barrel and cooling unit in their designated spots. (See 2.1 Figure)
Tip: Ensure the environment is well ventilated.
- **Weight:** A filled IceBarrel with one person = approx. **760 kg**.
 - Spread across 1,969 m² → **386 kg/m²** load.
- **Check load capacity:** Ensure the building structure can safely support this weight.

Cooling motor clearance:

- The cooling engine expels heat into the room, which needs to be regulated following the instructions mentioned in point '4. Conditions for Safe Usage.'
- It's important that when setting up the Icetub there is at least also **50 cm clearance** around the engine protector.

2.1 Figure. Positioning of IceBath XL & Cooling Engine

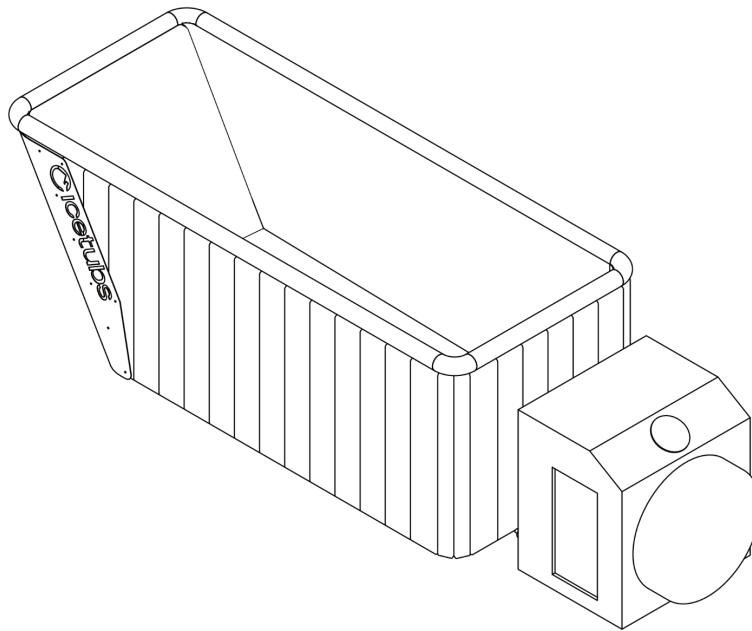

Step 3. Level the Tub and Cooling Unit

- Align the cooling unit's inlet and outlet with the connections on the Icetub, then adjust the leveling feet under both the Icetub and the cooling unit with a **16 mm** wrench for Icetubs until they are perfectly aligned and stable.

Step 4. Attach the Engine connectors

- Attach the two engine connectors with rubber seals to the lower inlet and top outlet of the water loop between the engine and the Icetub (See 4.1 Figure). Please note that the rubber seals were provided with the engine connectors.
- Connect the other ends of the connectors, also with rubber rings in place, to the cooling unit.

Note: Do not turn on the cooling unit yet!

4.1 Figure. Engine Connectors' location.

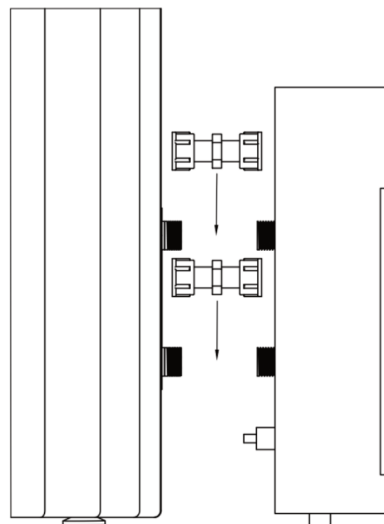

Step 5. Rinse the IceBath XL

- Remove the cap from the drain pipe, rinse the tub thoroughly, and drain the water completely. (See Figure 5.1)
- (Optional but recommended) Install the **drain attachment** provided together with the Icetubs for easier draining in the future. Make sure it's not left open before filling up the IceBarrel.(See Figure 5.2)
- If drain attachment is not installed, reinstall the cap of the drain pipe.

5.1 Figure. Rinsing the IceBath.

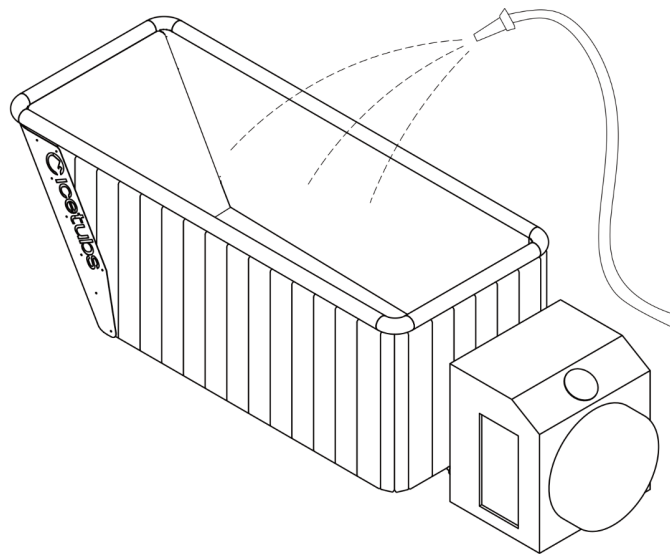

5.2 Figure. Gardena Drain Hose Attachment.

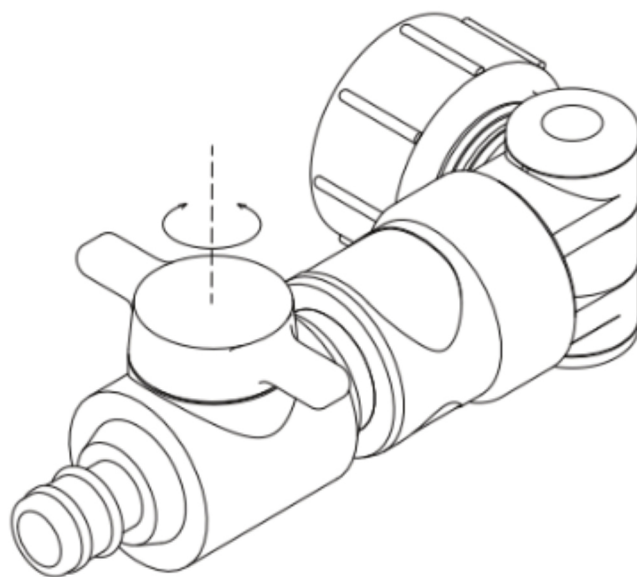

Step 6. Prepare the IceBath

- Once the water level reaches the **top outlet of the water** loop between the cooling unit and the Icetub, flush out any air from the system:
 - Hold your **garden hose** against the **top outlet and then bottom inlet** separately to push out air.
 - Fully **submerge the filter** under water in the Icetub to release all trapped air.
 - Screw the filter onto the **bottom connection (inlet) of the water loop inside the Icetub**. This prevents debris from entering the system and ensures smooth operation. (See 6.1 Figure)

Important note: Never use Icetubs without a filter installed, as this will result in engine failure over time and voids warranty!
- Install the metal seat, that goes above the filter. (See 6.2 Figure)
- Check that all connectors are watertight and not dripping water. Tighten further if necessary. (See 6.3 Figure)
- Fill the Icetub with water up to **20 cm from the rim**, considering your body weight and height. (See 6.4 Figure)

6.1 Figure. Installing the Filter on the lower inlet in the IceBath XL.

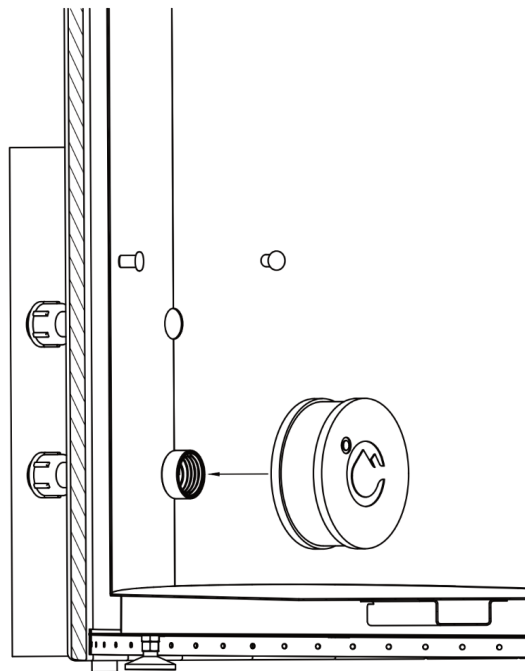

6.2 Figure. Leakage checking.

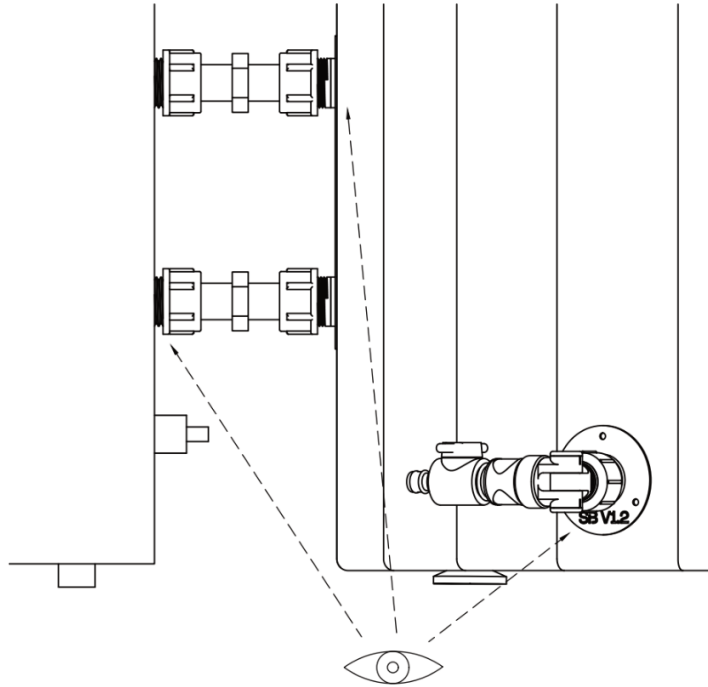

6.1 Figure. Filled IceBath XL.

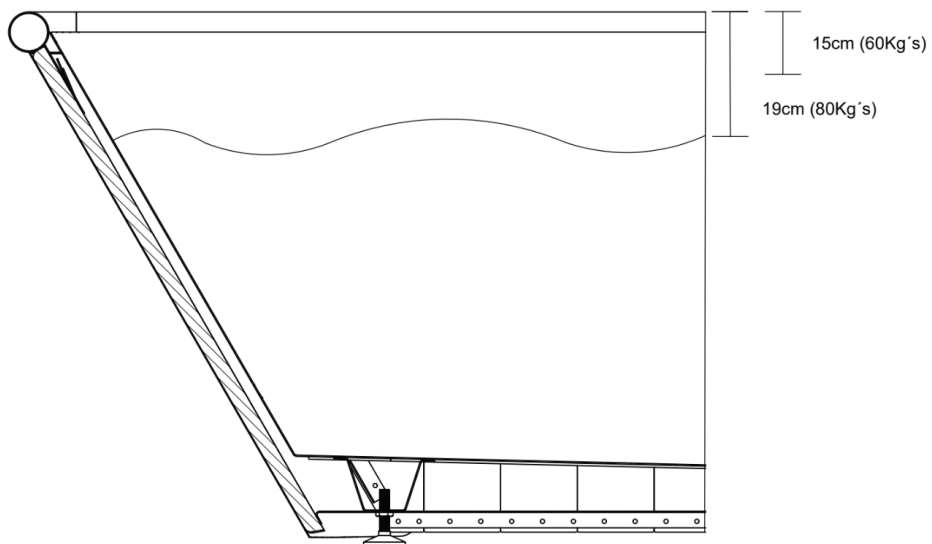

Step 7. Prepare the Engine

- Plug the cooling unit into a grounded outlet. Ensure the small box that's on the cable (**circuit breaker**) is **hanging against the wall** and not lying on the ground.
Important: The power cable and the circuit breaker is **water-resistant, not waterproof**, if your setup is outdoors, you must ensure that is **protected from rain and direct moisture**. (See 7.1 Figure)
- Press the **“ON”** button to turn on the cooling unit. Confirm that the circuit breaker is in the **ON** position. (See 7.2 Figure)
- Set the engine Automatic mode by pressing the **“M”** button until the **‘AUTO’** mode appears. (Automatic mode is able to cool and heat the water at the same time) (See 7.3 Figure)
- Set your desired temperature using the **“↑”** and **“↓”** buttons.
- Use the Icetubs app to adjust the settings remotely (ensure the cooling unit is close to your router for a stable connection):
 - Download the application in **Google Play Store or App Store**
 - Follow the instructions in the app to connect your Icetubs engine and control it remotely.
- It's recommended to read the tips & tricks in the app on how to adjust your Icetubs usage routine to progress efficiently.

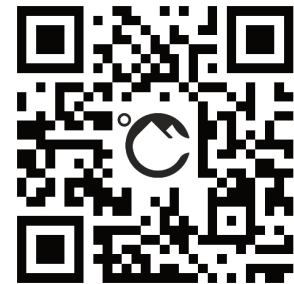

7.1 Figure. Electrical Outlet with grounding pins schematic.

Type F Socket

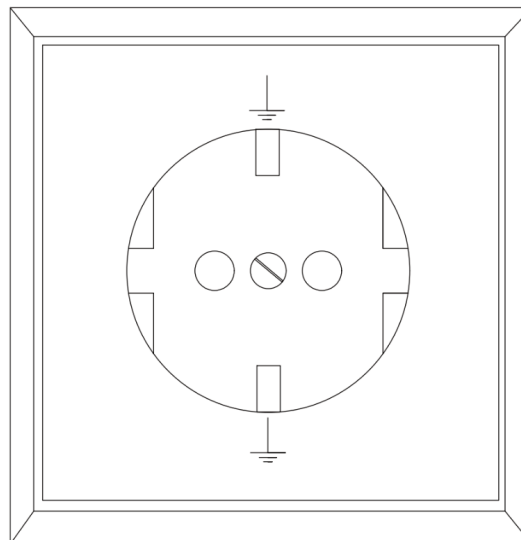

7.2 Figure. Cooling Engine's Control Panel. "ON" button highlighted.

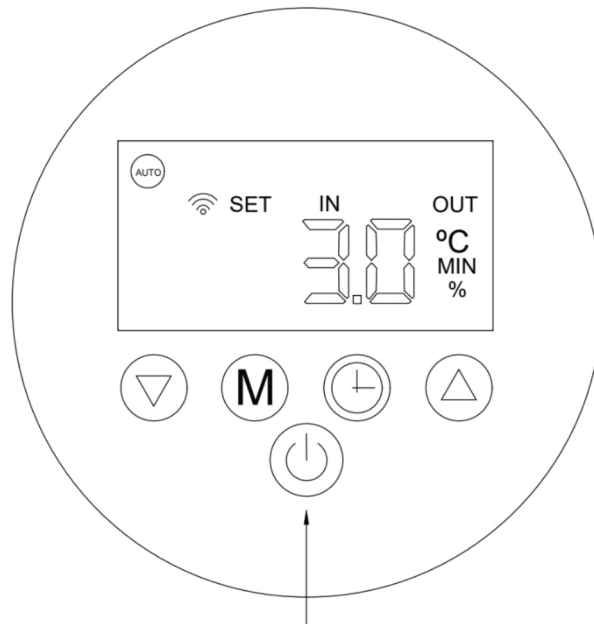

7.3 Figure. Cooling Engine's Control Panel. "M" button highlighted.

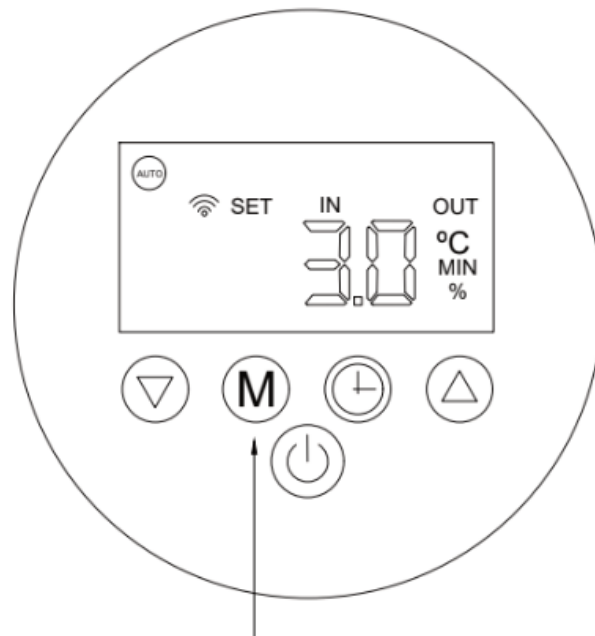

Step 8. Finishing the setup

- Place the Icetub Thermo cover on top. **Important:** If your Icetub is placed outside, it's recommended to **screw in the Icetubs Thermo cover clips** into the wood to prevent it from being swept away by wind. The screws should go in the **middle of the board**. (See 8.1 Figure & 8.2 Figure)
- **If you purchased the AquaFinesse Water Treatment All-in-One**, add the **weekly dosage** only **after** the Icetub has been filled. Then continue adding the weekly dosage every week. Dosage instructions can be found on support.icetubs.com.

8.1 Figure. Installing the IceBath's Cover.

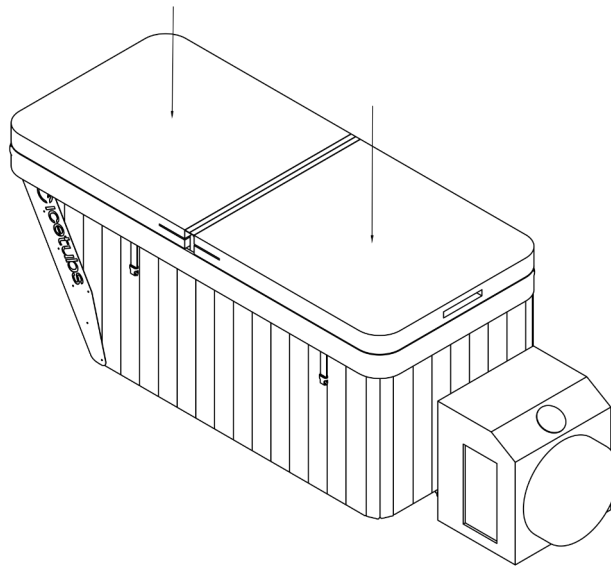

8.2 Figure. Cooling Engine's Protector.

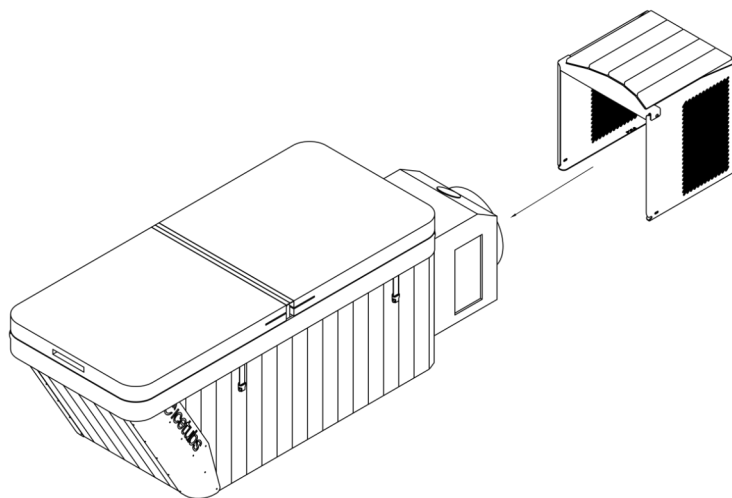

5.8 Setting up the IceKube

Step 1. Unpacking

- Remove the zip ties and take out the cardboard boxes and protective materials.
- Keep the engine standing for 24h before operation
- Immediately inspect for any damage. **If you notice anything, contact us at: service@icetubs.com**

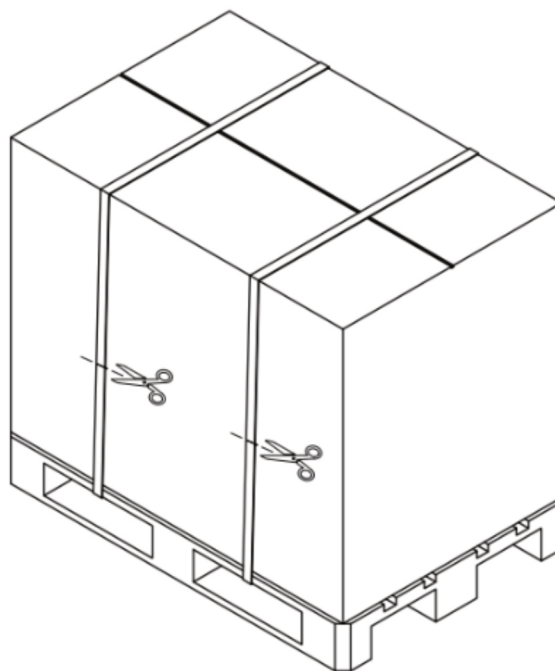

Step 2. Position the Components

- Place the barrel and cooling unit in their designated spots. (See 2.1 Figure)
Tip: Ensure the environment is well ventilated.
- **Weight:** A filled IceBarrel with one person = approx. **550 kg**.
 - Spread across 1,31 m² → **421 kg/m²** load.
- **Check load capacity:** Ensure the building structure can safely support this weight.

Cooling motor clearance:

- The cooling engine expels heat into the room, which needs to be regulated following the instructions mentioned in point '4. Conditions for Safe Usage.'
- It's important that when setting up the Icetub there is at least also **50 cm clearance** around the engine protector.

2.1 Figure. Positioning of IceKube & Cooling Engine

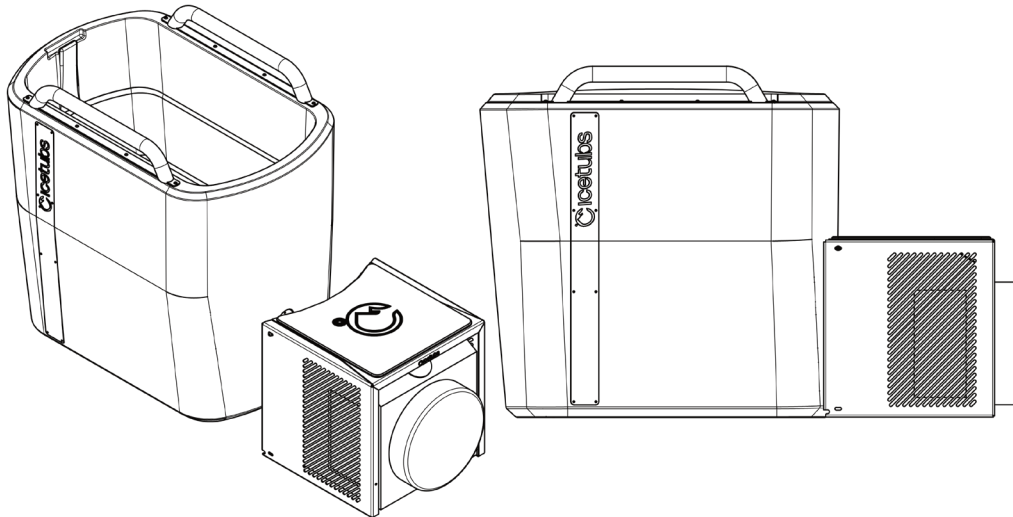

Step 3. Level the Tub and Cooling Unit

- Align the cooling unit's inlet and outlet with the connections on the Icetub.

Step 4. Attach the Engine connectors

- Attach the two engine connectors with rubber seals to the lower inlet and top outlet of the water loop between the engine and the Icetub (See 4.1 Figure). Please note that the rubber seals were provided with the engine connectors.
- Connect the other ends of the connectors, also with rubber rings in place, to the cooling unit.

Note: Do not turn on the cooling unit yet!

4.1 Figure. Engine Connectors' location.

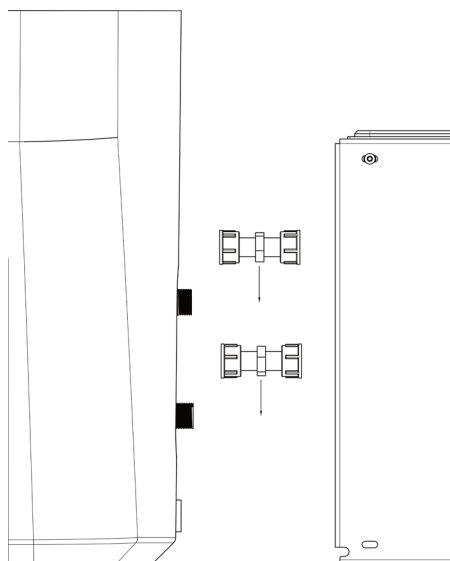

Step 5. Rinse the IceKube

- Remove the cap from the drain pipe, rinse the tub thoroughly, and drain the water completely. (See Figure 5.1)
- (Optional but recommended) Install the **drain attachment** provided together with the Icetubs for easier draining in the future. Make sure it's not left open before filling up the IceBarrel. (See Figure 5.2)
- If drain attachment is not installed, reinstall the cap of the drain pipe.

5.1 Figure. Rinsing the IceKube.

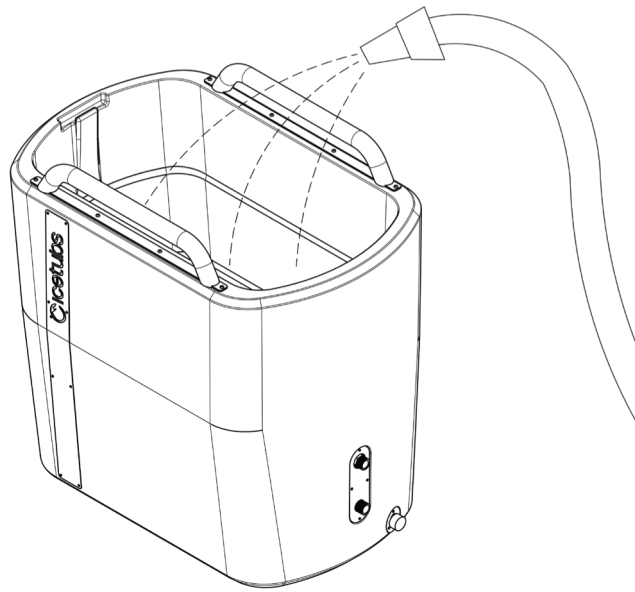

5.2 Figure. Gardena Drain Hose Attachment.

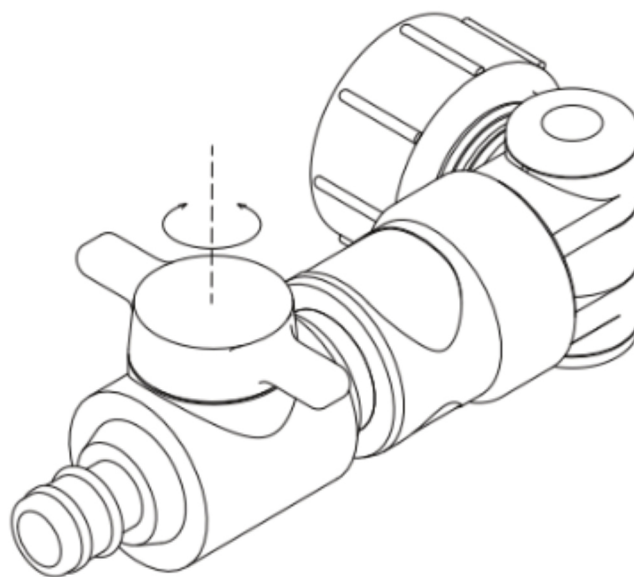

Step 6. Prepare the IceKube

- Once the water level reaches the **top outlet of the water** loop between the cooling unit and the Icetub, flush out any air from the system:
 - Hold your **garden hose** against the **top outlet and then bottom inlet** separately to push out air.
 - Fully **submerge the filter** under water in the Icetub to release all trapped air.
 - Screw the filter onto the **bottom connection (inlet) of the water loop inside the Icetub**. This prevents debris from entering the system and ensures smooth operation. (See 6.1 Figure)
- Important note:** Never use Icetubs without a filter installed, as this will result in engine failure over time and voids warranty!
- Check that all connectors are watertight and not dripping water. Tighten further if necessary. (See 6.2 Figure)
 - Fill the Icetub with water up to **25 cm from the rim**, considering your body weight and height. (See 6.3 Figure)

6.1 Figure. Installing the Filter on the lower inlet in the IceKube

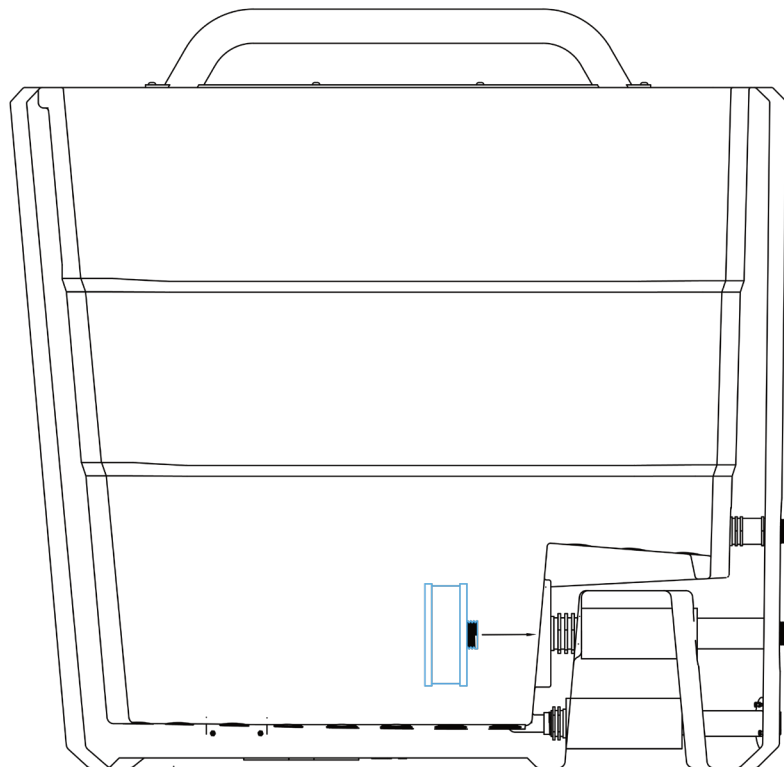

6.2 Figure. Leakage checking.

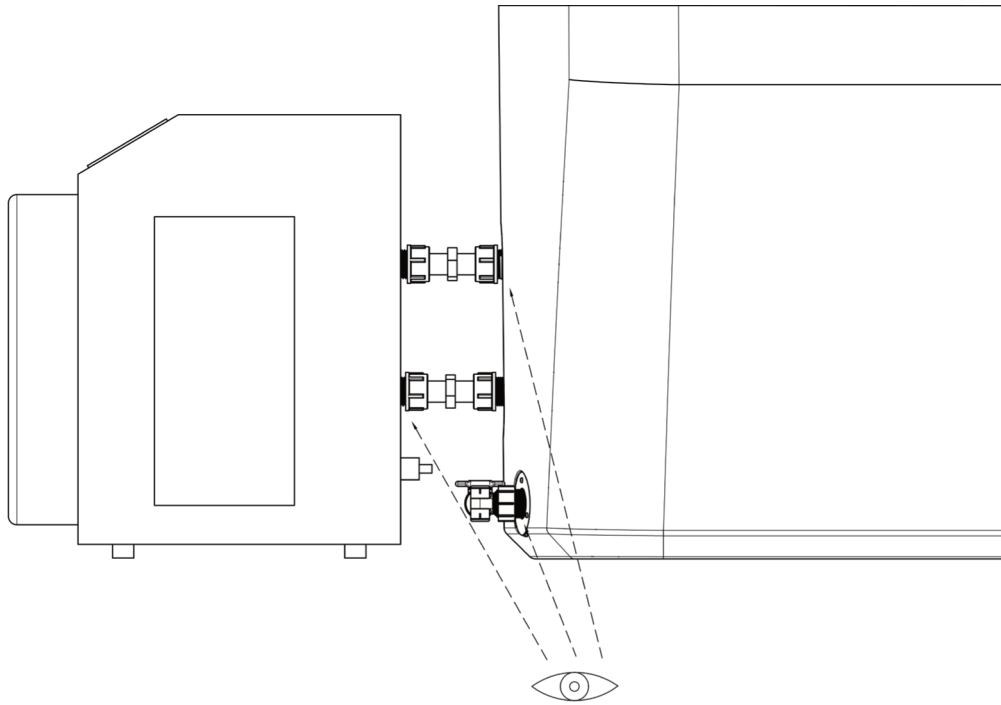

6.1 Figure. Filled IceKube.

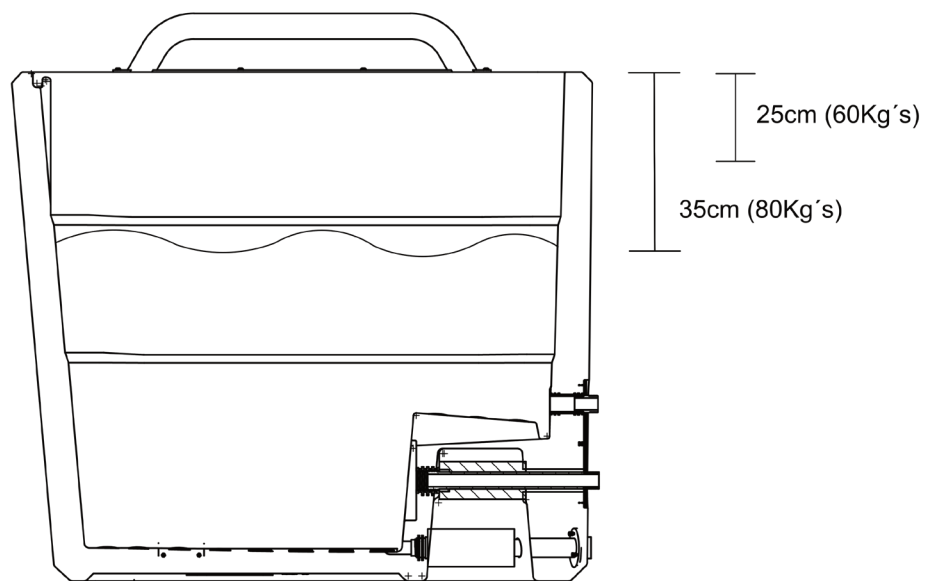

Step 7. Prepare the Engine

- Plug the cooling unit into a grounded outlet. Ensure the small box that’s on the cable (**circuit breaker**) is **hanging against the wall** and not lying on the ground.
Important: The power cable and the circuit breaker is **water-resistant, not waterproof**, if your setup is outdoors, you must ensure that is **protected from rain and direct moisture**. (See 7.1 Figure)
- Press the **“ON”** button to turn on the cooling unit. Confirm that the circuit breaker is in the **ON** position. (See 7.2 Figure)
- Set the engine Automatic mode by pressing the **“M”** button until the **‘AUTO’** mode appears. (Automatic mode is able to cool and heat the water at the same time) (See 7.3 Figure)
- Set your desired temperature using the **“↑”** and **“↓”** buttons.
- Use the Icetubs app to adjust the settings remotely (ensure the cooling unit is close to your router for a stable connection):
 - Download the application in **Google Play Store or App Store**
 - Follow the instructions in the app to connect your Icetubs engine and control it remotely.
- It’s recommended to read the tips & tricks in the app on how to adjust your Icetubs usage routine to progress efficiently.

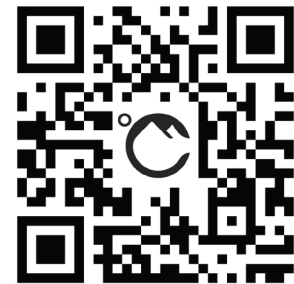

7.1 Figure. Electrical Outlet with grounding pins schematic.

Type F Socket

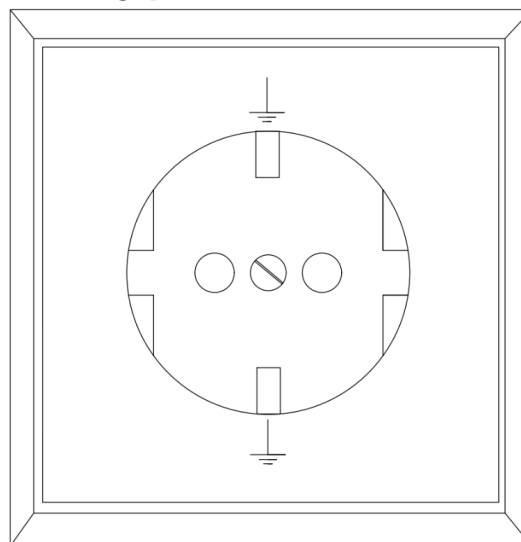

7.2 Figure. Cooling Engine's Control Panel. "ON" button highlighted.

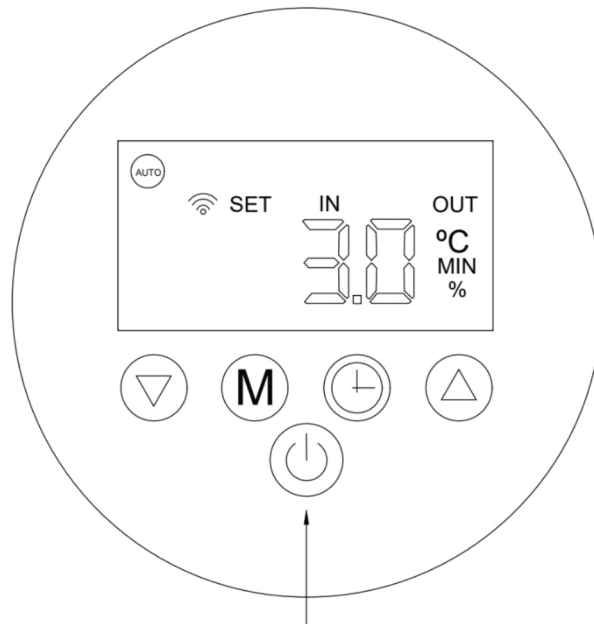

7.3 Figure. Cooling Engine's Control Panel. "M" button highlighted.

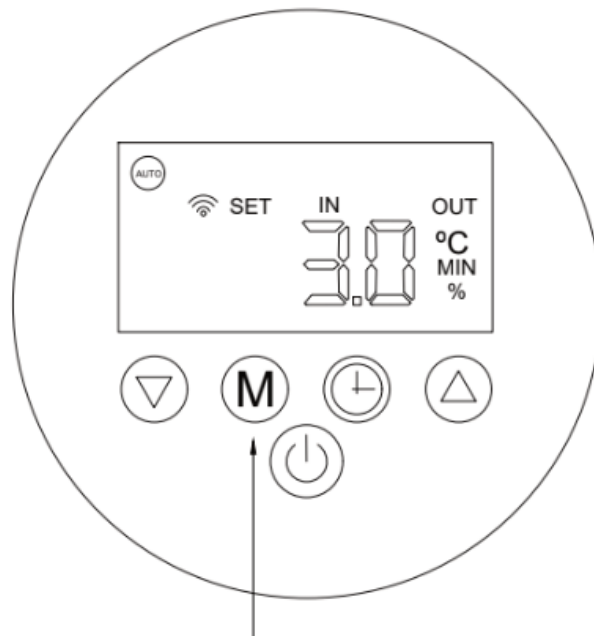

Step 8. Finishing the setup

- Place the IceKube Lid cover on top. (See 8.1 Figure & 8.2 Figure)
- **If you purchased the AquaFinesse Water Treatment All-in-One**, add the **weekly dosage** only **after** the Icetub has been filled. Then continue adding the weekly dosage every week. Dosage instructions can be found on support.icetubs.com.

8.1 Figure. Installing the IceKube's Lid

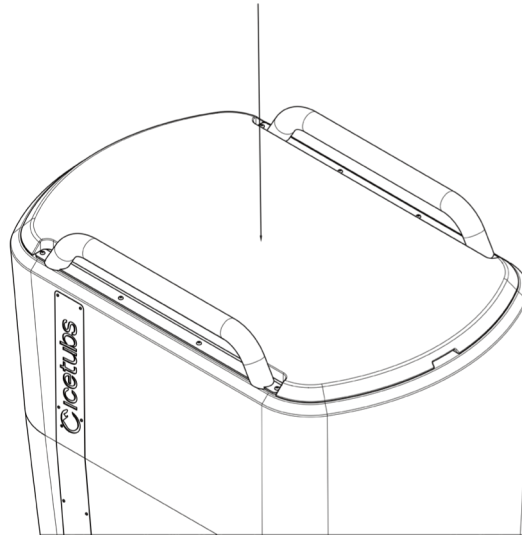

8.2 Figure. Cooling Engine's Protector.

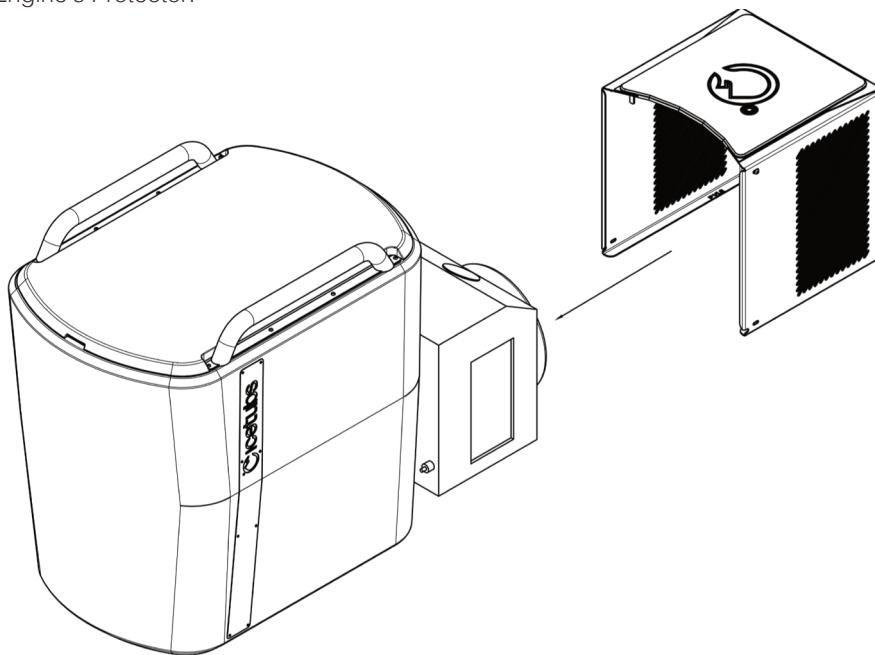

5.9 Setting up the Phone Holder

The Phone Holder adds simple, hands-free control to your cold plunge sessions. Use it to keep track of your timer, play music, or record your plunge with ease.

The Phone Holder consists of three parts:

- Attachment plate, mounted to the wood
- Stainless steel adjustment tube
- Phone holder clamp

Installation steps:

1. **Choose the position:** Select a mounting location that is easy to see and reach. Most users install the holder in front of their sitting position.
2. **Position the attachment plate:** Place the plate on a single wooden plank. Do not mount it across gaps between planks.
3. **Check Thermo cover clearance:** Place the Thermo cover on the tub to confirm it can still move freely up and down after installation.
4. **Insert the first screws:** This step is easiest with two people. One person holds the Phone Holder in place while the other installs the first two screws.
5. **Secure the holder:** Install the remaining four screws and ensure the holder is firmly fixed.
6. **Ready to use:** Place your phone in the clamp and start your timer, play music, or record your session hands-free.
7. **Adjust the angle:** Turn the stainless steel tube counterclockwise to loosen it. Adjust to your preferred angle, then tighten clockwise to lock it in place.

5.10 First Test Run

After completing the installation of your Icetub, it is time for the first test run. Please follow the steps below for a successful test run, before you try your Icetub.

1. **Turn on the Engine:** Turn on the engine and check if everything is working. Make sure there are no errors on the screen, and that the pump is circulating the water.
2. **Check for leaks:** Make sure water is not dripping from the engine connectors, drain cap or the drain attachment if installed.
3. **Setting the Engine to temperature:** Set your desired temperature by using the “Up” and “Down” buttons. Use the cooling mode only to cool the water, or heating mode only to heat the water. It’s recommended to use Automatic mode, since it can do both at the same time.

Note: During cold/hot temperatures, when the engine is set to Automatic mode it can heat up the water when it’s going below your desired temperature, or cool it down if it goes above your desired temperature. Please drain and disconnect the engine if the temperature goes below -5°C or above 40°C. Please drain and disconnect below 1°C if the engine is left off when it’s not in use.

4. **Check Water Level:** Make sure the tub is completely filled. (Water line should be not less than 20 cm from the rim) If no errors, or leaks have occurred, the test is complete. If any errors appeared please follow below instructions for troubleshooting. If they do not help resolve the issue, please contact: service@icetubs.com, we will get back to you between 1 and 2 business days.

5.11 Tips & Tricks After Installation

1. For long-lasting preservation of your Icetub, and clean frequent usage, make sure to change your filters monthly. It's important to use only Icetubs filters, for full product compatibility and proper functioning of your Icetub. You can order your filters, and even subscribe to monthly deliveries on our website [\(link\)](#).
2. Make sure your engine is running for at least 6 hours a day, to prevent standing water causing excessive bacteria growth. When the engine runs in automatic mode, energy consumption remains low, as it only activates when needed to maintain temperature.
3. Cooling schedules can be useful to reduce background noise from the engine, for example during the night. However, the energy savings from using schedules are negligible, since the engine consumes very little power in automatic mode. What matters most is consistent circulation.

In real-life use, when the engine runs continuously and the tub is used daily by one person, the water and filter typically only need to be replaced every 1 to 2 months. When circulation is reduced, water quality deteriorates faster, which leads to more frequent maintenance and earlier water changes.

While reducing engine runtime may seem like a way to save electricity, it often results in higher maintenance effort and costs over time. Regular circulation is the most reliable way to keep your tub clean, stable, and easy to maintain.

Cooling Engine Operation

Please read this section carefully before installing or operating the cooling engine.

6.1 Safety & Warnings

Always follow these safety rules when installing or operating the Cooling Engine:

- Keep the **main power switch out of reach of children**.
- This device is **not for direct use by children**.
- Confirm **correct power supply, voltage, and frequency** before installation.
- Turn off the **main power supply during thunderstorms** to prevent damage.
- Keep all **ignition sources** away from this device. Risk of fire or explosion.
- Do not store **flammable, explosive, or toxic substances** near the cooling unit.
- If a **refrigerant leak** occurs during installation or use, stop all operations immediately.
- Do not operate with **wet hands** (risk of electric shock).
- Do not insert **fingers or objects** into ventilation openings (high-speed fan hazard).
- Do not clean the unit while powered. Always **turn off power before cleaning**. **For correct maintenance and cleaning, follow the instructions provided in this manual**.
- Improper operation may cause **injury or equipment damage**.
- If ambient temperature drops below **-5 °C**, drain both the **cooling system and Icetub** to prevent freeze damage (not covered by warranty).
- Store and transport the unit **vertically in original packaging**. If placed on its side, wait **24 hours upright** before powering on.
- Improper installation may cause **fire, electric shock, water leakage, or equipment failure**.
- Do not place **objects within 50 cm of the air inlet or outlet**. Obstruction reduces efficiency and may trigger faults.
- Always run the engine with a filter installed. The unit must not run without a filter installed (required for warranty).

- **When the engine is on** and the ambient temperature is below -5°C or above 40°C, move the engine indoors to prevent the water from freezing. If the water freezes and pipes burst - this is not covered under warranty. If the engine overheats and stops working due to extreme heat - it's not covered under warranty.
- **When the engine is off** and the ambient temperature is below 1°C or above 40°C, move the engine indoors to prevent the water from freezing. If the water freezes and pipes burst - this is not covered under warranty. If the engine overheats and stops working due to extreme heat - it's not covered under warranty.

6.2 Precautions

- Inspect the unit upon receipt: check condition, fasteners, and quantity.
- Before installation: cut packing belts, remove packaging, remove wooden tray. Dispose of plastic wrappings safely.
- If a serious **refrigerant leak** is suspected, extinguish/remove open flames nearby.
- Install, operate, and maintain in a **well-ventilated area** only.
- Follow all **local laws, regulations, and standards**.
- All units are equipped with **GFCI circuit breakers**. If a ground fault occurs, the system shuts down. Connect the cooling unit only to a **grounded outlet protected by a GFCI breaker** in the main panel.
- Route the **power cable safely**. Protect against wear, sharp edges, corrosion, and vibration. Secure all connections.
- If a **leak** is detected at inlet/outlet piping, turn off the equipment immediately.
- If the unit does not operate properly or shows a **fault code**, stop operation and contact Icetubs Service (See Chapter 10.4 for contact information).
- Replace components only with **original Icetubs parts** as specified by the manufacturer.

6.3 Electrical Installation

To ensure safe operation and protect the integrity of the electrical system, connect the equipment to the public power supply as follows:







1. Connect the cooling unit to a **circuit breaker** that meets national regulations.
2. Power cables and extension lines must be rated for the unit's power demand and suitable for outdoor use.
3. In public areas, install an **emergency stop switch** near the cooling device.
4. Always connect the cooling unit to a **grounded GFCI breaker outlet** in the main breaker panel.

6.4 Inspection

Before starting the system, confirm:









- The cooling device is correctly installed.
- Connectors are properly set up.
- The air outlet is unobstructed by at least 50 cm.
- No leaks in inlet or outlet pipes.

6.5 Display Operation

Symbol	Description
	Heating mode
	Cooling mode
	Automatic mode
	Defrost mode
	Networking function
	ozone icon



6.5.1 Screen icons & keys

-  **Lock indicator** – shows when the screen is locked.
-  **Power (On/Off)** – toggles the unit on or off.
-  **Auto Mode** – indicates automatic operation.
-  **Time key** – sets the real-time clock and opens timer menus.
-  **Mode/Lock key** – switches modes; press-and-hold to lock/unlock the screen.
-  **“+” key** – increases values (temperature, hours/minutes, etc.)
-  **“-” key** – decreases values (temperature, hours/minutes, etc.)
-  **Wi-Fi icon** – shows wireless status; used in quick connection.
-  **Ozone icon** – shows when ozonator is on. It will come on half of the time while pump is working. If it's blinking that means it's on manual mode. Please change it back to automatic mode by holding “Up” and “Down” buttons for 5-10 seconds.

Tip: In the steps below, **press** means a short press; **press and hold** means hold ~3seconds until you hear a beep.

6.5.2 Operation

Power & Screen Lock

- **Lock/Unlock:** Press and hold **Power/Lock** for ~3seconds until a **beep**. The Lock icon turns **off**.
- **Power On/Off:** Press **Power (On/Off)** to toggle. When off, the controller shows **OFF**. Display will still be visible once it's turned off.

Mode

- When power-up is on, the unit starts in **Automatic mode** (Auto icon lit).

Set Temperature

- With the unit on, press **“+”** or **“-”** to adjust the **set temperature**.

Fault Display

- On a fault, a **fault code appears**. Go to the troubleshooting graph of water not cooling and see how to solve the fault code.
- When the fault is cleared, the code **disappears automatically** (rarely you have to turn it off and on again)

Clock (Real-Time) Setting

1. From the main screen, **press and hold Time** for ~3seconds (hours & minutes flash).
2. **Press Time: hours flash**. Set hours with **“+”** / **“-”**.
3. **Press Time: minutes flash**. Set minutes with **“+”** / **“-”**.
4. **Press Time to confirm** and return to the main screen.

Note: At any point in clock setup, **press Time** to confirm current values and exit.

Power Switch Timer (On/Off Scheduler)

You can store two timer programs (**T1** and **T2**). Each has an **ON (start)** and **OFF (stop)** time.

Set timer times

1. From the main screen, **press Time** to open **Timer Groups**. **T1 flashes**.
2. **Press Time** to edit **T1 ON** hour (hours flash). Set with **“+”** / **“-”**.
3. **Press Time** to edit **T1 ON** minutes. Set with **“+”** / **“-”**.
4. **Press Time** to edit **T1 OFF** hour; set with **“+”** / **“-”**.
5. **Press Time** to edit **T1 OFF** minutes; set with **“+”** / **“-”**.
6. **Press Time** to confirm **T1**. Use **“+”** / **“-”** to select **T2** and repeat.

Enable/Disable a timer group

1. From the main screen, **press Time** to open **Timer Groups**.
2. Use **“+”** / **“-”** to select **T1** or **T2**.

3. Press and hold Time for ~3 seconds to enable/disable the selected group.
 - When enabled, the group's timer icon shows on the main screen.

Important: If a group's ON time equals its OFF time, that group is invalid and won't run.

Key Lock (Manual)

- **Manual lock:** From the main screen (unlocked), **press and hold Power button** for ~3 seconds (beep, Lock icon on).
- **Unlock:** **Press and hold Power button** for ~3 seconds (beep, Lock icon off).

Wireless Network (Wi-Fi)

- **Quick connect mode:** **Press and hold Clock and Up** buttons together for ~3 seconds. The **Wi-Fi** icon **flashes** to indicate pairing mode.

Complete setup in the Icetubs app while the icon is flashing. Scan the QR-code to download the Icetubs app.vv

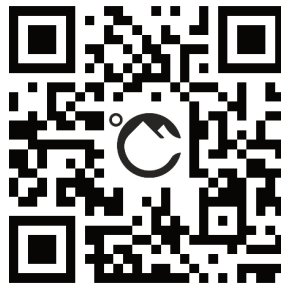

7 Maintenance & Water Hygiene

7.1 Requirements

Proper maintenance and water hygiene ensure safe, reliable, and long-lasting operation of the Icetub and its cooling engine.

Because the Icetubs hold a relatively small water volume (about 350–500 L), contaminants build up quickly. The following tools and products are required for regular cleaning, water treatment, and engine protection:

7.1.1 Cleaning and general care

- **Paper towels:** For wiping the barrel when empty and during general cleaning.
- **Microfibre cloths:** For polishing stainless steel surfaces without scratching.
- **Sodium bicarbonate:** For cleaning the waterline and removing body oils, scum or residue buildup.
- **Anti-bacterial cleaner:** For wiping down the insulated cover, side panels, steps/deck, and exterior surfaces as needed.
- **Wet/dry vacuum or spa-vac (optional):** Useful for removing debris from the bottom of the barrel when draining water or during deep cleaning.

7.1.2 Water treatment and chemicals

- **AquaFinesse watercare:** The only recommended water treatment. Do not use chlorine, bromine, salts, or aggressive chemical additives.
- **Certified replacement filters (5-micron cartridge):** Use only genuine Icetubs filters. These are required for safe and proper operation; running the Icetub without a filter can damage the cooling engine and void the warranty.

Important: Do not use chlorine, acids, salts, or other harsh chemicals, they can damage the stainless steel insert and internal plumbing, and will void warranty.

7.1.3 Testing equipment

- **Digital water tester or test strips:** To monitor pH and water hardness periodically (especially after fresh fill).
- **Spare filter cartridges:** Always keep at least one spare genuine filter so you can replace immediately if needed.

7.1.4 Optional service tools

- **System-flush solution:** E.g., Mild spa-safe cleaner (non-chlorine) suitable for internal plumbing, used during major water changes.
- **Protective gloves:** When using cleaning agents.
- **Extra microfibre cloths / stainless-steel cleaning cloths:** For drying and polishing after cleaning.

7.2 Basic Principles of Hygiene

Maintaining proper water hygiene in the Icetub is essential for both user safety and long-term engine health. Given the small volume, each user significantly impacts water quality. Without proper care, oils, sweat, cosmetics, and debris accumulate quickly, potentially harming water quality and impairing water circulation.

7.2.1 Basic principles of hygiene

1. **User hygiene first:** Always encourage users to shower before entering (remove sweat, oils, sunscreen, fake tan, etc.). This reduces the load on filters and makes water treatment more effective.
2. **Debris control:** Remove leaves, hair, particles, or other visible debris before and after each use. Clean water entering the filtration system prolongs filter life and protects the engine.
3. **Water dilution / refresh:** Depending on use, refresh (drain & refill) water every 1 to 2 months. More frequent changes may be required with frequent use or poor pre-shower compliance.
4. **Filter maintenance:** Use genuine Icetubs filters only; replace regularly according to usage (see below). Do not run the system without a filter.
5. **AquaFinesse dosing:** Add the recommended amount weekly to control biofilm, soften water, and maintain clarity without harsh chemicals (see Chapter 7.4 for more instructions on AquaFinesse).

7.2.2 Importance of balanced water

Balanced water is not just clean water - it is water where chemical, physical, and biological factors are in harmony. Proper balance protects the health of users, ensures effective sanitation, and extends the life of the Icetubs components.

1. **Water hardness & pH:** While AquaFinesse helps stabilise water, periodically check water hardness and pH especially after fill or heavy use.
2. **Never use chlorine / acids / salts / bromine:** These damage stainless steel and void the warranty. Always adhere to AquaFinesse-based treatment.

Continuous system protection: Keep the engine running when the barrel is filled and in use. The built-in ozonator provides

background sanitation. Turning off the engine for extended periods increases the risk of bacterial growth.

7.3 Maintenance To-Do List

Tip for operators: The more effort users put into hygiene before bathing, the less strain is placed on filters, chemicals, and mechanical components.

7.3.1 Daily / after use – quick cleaning and checks

- Wipe the waterline and interior stainless using a damp microfibre cloth. For stubborn scum or residue, use a mixture of water and a little sodium bicarbonate and gently rub with the grain.
- Ensure water is clear and circulating properly (engine running, no flow issues).
- Skim and/or remove debris (hair, leaves, dust) from the water surface or bottom.
- Visually check the water for clarity, unusual colour, or odour — especially after heavy use.

7.3.2 Weekly – water treatment & filter Inspection

- Dose AquaFinesse per instructions for the Icetub volume (weekly).
- Inspect the filter: if water flow or clarity degrades, consider replacing.
- Clean external surfaces: wipe down outer shell, cover, panels, and any stainless components with anti-bacterial cleaner.
- If the Icetub is covered when not in use, ensure the cover stays on to prevent debris accumulation.

7.3.3 Monthly – filter replacement & water refresh

- Replace the cartridge filter once **per month** under typical usage (1 user, daily, showering before use). This aligns with Icetubs' official recommendation.
- If water quality degrades or user frequency is high, consider replacing more often.
- After refill, wait for proper circulation and dose AquaFinesse.

7.3.4 Every 1–2 months (or as needed) — full Water change & deep clean

- Drain the Icetub fully.
- Clean all stainless-steel surfaces thoroughly using a suitable non-abrasive stainless-steel cleaner and microfibre cloth.
- Rinse the tub interior thoroughly with clean water.
- Optionally, perform a gentle system flush using a spa-safe, non-chlorine cleaner, then refill the barrel with fresh water.
- Refill with fresh water. Start engine, ensure circulation, and dose AquaFinesse.
- Replace filter with a fresh cartridge.

7.3.5 Expected lifespan of wear parts

Some internal components will wear over time and may need replacement. Typical lifespans under proper maintenance:

- **Pump (circulation / cooling):** approx. **30,000 hours** (~3.5 years)
- **Built-in ozone generator:** approx. **10,000–15,000 hours** (~2.5–3 years)

Because the filter is designed for single use only, do not reuse old cartridges unless necessary; replace them when saturated.

7.3.6 Replace the filters

Regular filter replacement ensures optimal performance and extends the lifespan of your Icetubs system.

Steps:

1. **Turn off and unplug the system**
 - Make sure the unit is powered down and disconnected from the outlet before starting.
2. **Access the filter**
 - Locate the filters positioned inside the Icetub on the bottom inlet, near the connection to the engine.
3. **Remove the old filter**
 - Twist the filter counterclockwise (lefty loosey).
 - Carefully take it out of the tank.
4. **Prepare the new filter (to prevent a PL error)**
 - Hold the new filter upside down (thread pointing up) in the water.
 - Wait until all air bubbles have escaped.
5. **Install the new filter**
 - Screw the replacement filter clockwise (righty tighty) into the connection.
 - Ensure it is snug and secure.
6. **Test the system**
 - Fill the water until the filter is fully submerged if water was drained.
 - Plug the unit back in and power it on. Check for smooth operation.
 - Fill the water up to 20-40 cm (depending on Icetub and body weight) from the rim if water is drained.

7.4 AquaFinesse Instruction Guide

7.4.1 Getting started

Follow these steps to keep your Icetubs water clean, safe, and environmentally friendly.

7.4.2 What's in the box

- 1 liter AquaFinesse Icetubs Water Care Liquid
- 1 measuring cup
- These instructions

7.4.3 Weekly water care

1. Shake the AquaFinesse bottle well before use.
2. Once a week (preferably on a fixed day) measure and add the correct amount using the included measuring cup.
 - a. See the recommendation below, or the label on the back of the bottle, for dosage.
 - b. The recommended dose remains fully effective within a $\pm 30\%$ range, so there's no need for perfect precision. Your water quality and system performance will stay consistent.
 - c. Pour evenly across the water surface.

7.4.4 Recommended weekly dosage

The following recommended weekly dosage is based on typical 80% tub fill.

- IceBarrel: 40 ml
- IceBarrel XL: 60 ml
- IceBath: 60 ml
- IceBath XL: 60 ml

After refilling the Icetub with clean water, use half of the dosage mentioned above for the first treatment.

7.4.5 Important safety info

- Do not mix with other water treatment products and chemicals.
- Always close the child-proof cap after use and keep it out of reach of children.
- If ingested or in contact with eyes in undiluted format, wash thoroughly with water and consult a physician.

7.5 Caring for ThermoWood Exterior

The Icetub is wrapped in durable ThermoWood, selected for its structural stability, weather resistance, and timeless natural look. Although ThermoWood performs exceptionally in outdoor environments, it still requires simple yearly maintenance to preserve its colour, texture, and longevity.

7.5.1 Why thermowood needs care

ThermoWood is heat-treated softwood designed to resist swelling, shrinking, and moisture absorption.

However, long-term exposure to:

- UV light
- Rain and humidity
- Heat and cold cycles
- Outdoor pollutants

Can cause:

- Fading or greying of the wood
- Dryness
- Surface cracking
- Loss of natural richness

A **once-a-year oiling routine** keeps the wood protected, hydrated, and visually appealing.

7.5.2 How to maintain thermowood

1. Clean the Surface

- Remove dirt, dust, and debris using a damp cloth or soft brush.
- Do NOT use pressure washers — they damage the wood fibres.
- Do NOT use chlorine, salts, acidic cleaners, or abrasive chemicals.

2. Apply Wood Oil (Oak Light Stain)

To restore colour, protect against UV fading, and prevent drying:

- Use Oak Light Stain wood oil (Icetubs recommended).
- Apply using a clean rag or sponge, moving in the direction of the grain.
- Let the oil absorb fully into the wood.
- Wipe off any excess to prevent a sticky or uneven finish.

One coat per year is sufficient for standard outdoor use.

3. Best Conditions for Oil Application

For optimal results:

- Choose a dry day
- Temperature between 10–25°C
- Avoid direct sunlight during application
- Do not apply if rain is expected

Proper drying ensures even absorption and long-lasting protection.

7.5.3 What to avoid

To prevent damage or premature wear:

- Do **not** use chlorine, salts, or harsh chemicals
- Do not let standing water sit on the wood for long periods
- Do not cover wet wood with airtight covers — it must be able to breathe
- Do not sand deeply unless advised by a professional

7.5.4 Extra notes

If the Icetub is placed in **strong sun, high humidity,** or **harsh winters,** additional oiling (1–2x per year) may help maintain colour and protection.

7.6 Thermo Cover Care

Important: Even when the tub is empty and not in use, condensation can build up underneath the cover. Always leave the drain valve open so moisture can escape.

7.6.1 Daily use

- Unfasten all straps before opening the cover. Fold the cover back gently onto itself.
- Never sit, stand, or lie on the cover. Do not place heavy objects on top.
- Remove leaves, dirt, or debris regularly to prevent staining or discoloration.

7.6.2 Cleaning

- Clean the faux leather or vinyl cover once per month using a mild detergent and water.
- Rinse thoroughly and let the cover dry before closing.

7.6.3 Water quality effect

- Maintain proper water chemistry at all times. Changes in texture or severe discoloration on the underside of the cover indicate chemical damage.

7.6.4 Weather and handling

- Do not allow snow to build up on the cover.
- Avoid dragging or scraping the cover over rough surfaces.
- Never pull or jerk the cover, especially when warm, as this can cause tearing.

User Guidance

8.1 User Safety

8.1.1 Important to know

- Keep exposure time short, around 1–3 minutes, depending on the water temperature and your personal preferences.
- Children may only use the ice bath under adult supervision, with reduced exposure times and warmer temperatures.
- If you have a medical condition, such as heart disease, bad circulation, respiratory issues, or high blood pressure, seek medical advice before using an ice bath.
- Enter and exit the ice bath slowly to avoid slipping or falling. Do not jump, dive, or drop into the ice bath, as this can cause accidents or damage to the unit.

8.1.2 Before you start

- Shower before you go into the ice bath to remove oils, lotions, or sweat from your skin that may compromise water quality.
- Make sure you're hydrated. Avoid drinking alcohol and eating heavy meals in the hour leading up to using the ice bath.
- Never use the Icetub alone. Having someone with you while you take an ice bath is crucial to supervise and ensure your experience stays safe.
- Enter the ice bath only when you are physically and mentally prepared for deliberate cold exposure: Decide consciously to enter: ensure your body and mind are ready for deliberate cold exposure.

8.1.3 During your session

- Enter the bath slowly and gradually to minimize the risk of cold shock.
- Submerge your body up to the neck if possible, keeping your head completely above water at all times.
- A single ice bathing session should last 1–3 minutes. Limit immersion to a maximum of 5 minutes or exit sooner if discomfort increases.
- Focus on controlled exposure rather than pushing endurance. The goal is safe, manageable discomfort. Pay attention to how your body feels, as tolerance can vary day to day.

8.1.4 After you've joined the cold

- Step out of the water slowly and carefully. Expect mild stiffness in your muscles and joints immediately after cold exposure.
- Pat your skin dry with a towel and avoid sharp temperature changes; warm up gradually.
- Wait until your heart rate and body temperature have returned to normal before considering a second session.
- Engage in some light exercise such as squats, horse stance, or light walking to promote circulation and warm the body safely.
- Feeling cold after a session is normal. Seek immediate medical attention if you experience severe shivering, numbness, disorientation, or loss of coordination – these may indicate hypothermia.

8.2 Contraindications & Risk Groups

Cold water immersion in the Icetub is not suitable for everyone. Certain individuals face increased risks and should avoid use unless cleared by a healthcare professional.

8.2.1 Medical conditions

- Serious heart or cardiovascular, including uncontrolled high blood pressure.
- Circulatory disorders or other significant illnesses that may affect blood flow.
- Epilepsy, fainting disorders, or conditions that affect body temperature regulation.
- Raynaud's syndrome or peripheral neuropathy.
- Respiratory conditions such as asthma or chronic lung disease.
- Recent surgery or injuries – use the Icetub only with medical clearance.

8.2.2 Temporary health risks

- Fever, cold, flu, or any infectious illness.
- Open wounds, sores, or skin infections.
- Immediately after intense exercise. Allow the body to recover and cool down first.
- Within one hour after a heavy meal.
- Under the influence of alcohol or drugs.

8.2.3 Specific groups

- Pregnant women, unless specifically approved by a healthcare professional.
- Children under 12 years old, unless medically advised and closely supervised.

8.2.4 Important notice

If you have any of the following pre-existing medical conditions or health concerns, please consult a doctor before using the Icetub. Your safety is always more important than a complete cold therapy session.

Trouble- shooting

Before starting any troubleshooting steps, always check the following:

- **Never run the Cooling Engine without water inside.** This will damage the system.
- **Never run the Cooling Engine without the filters installed.** Filters protect the system from dirt and damage.
- **Never cover the Cooling Engine air outlets.** Proper airflow is essential for safe cooling.

9.1 How Troubleshooting Works

Troubleshooting is carried out step by step.

Start with the main problem type:

- **Cooling / Water not cold enough** → Go to **Graph 9.2**
- **Water not clean / Smell / Bad values** → Go to **Graph 9.3**
- **Water level too low / Leakages** → Go to **Graph 9.4**

How to follow the diagram:

1. Begin at the top of the graph.
2. Read each question in order.
3. If the question applies, follow the arrow to the next step.
4. If you reach an action, perform it before continuing.

End result:

- Some issues can be solved directly by completing the steps.
- If the flowchart leads you to a service step, contact **Icetubs Service** for further support.

Each troubleshooting graph is designed as a flowchart. You will encounter four types of boxes:

- **Question boxes (brown):** Answer “Yes” or “No” and follow the arrow.
- **Action boxes (green):** Carry out the described step, then continue.
- **End boxes (beige):** Problem solved. You can keep using the Icetub.
- **End boxes (red):** Problem cannot be solved on-site. Contact Icetubs Service.

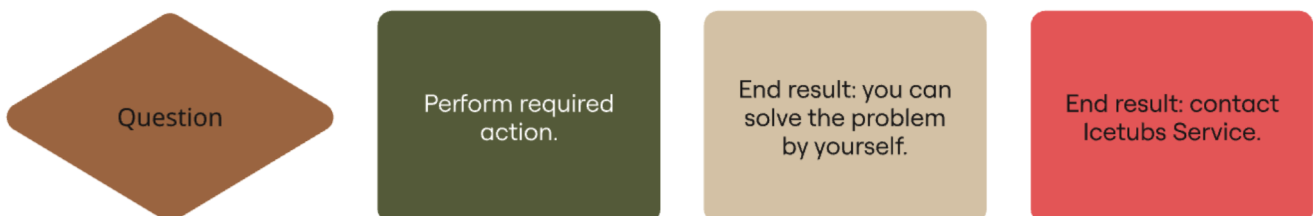

If troubleshooting leads you to a red box, contact Icetubs service.

Contact details: service@icetubs.com (+31) 33 200 3091

Provide the following information:

- A clear description of the problem.
- The troubleshooting graph you used and which steps you completed.
- Photos or videos of the issue, if possible.

This information helps our service team assist you quickly and effectively.

9.2 Troubleshooting “Water not Cooling”

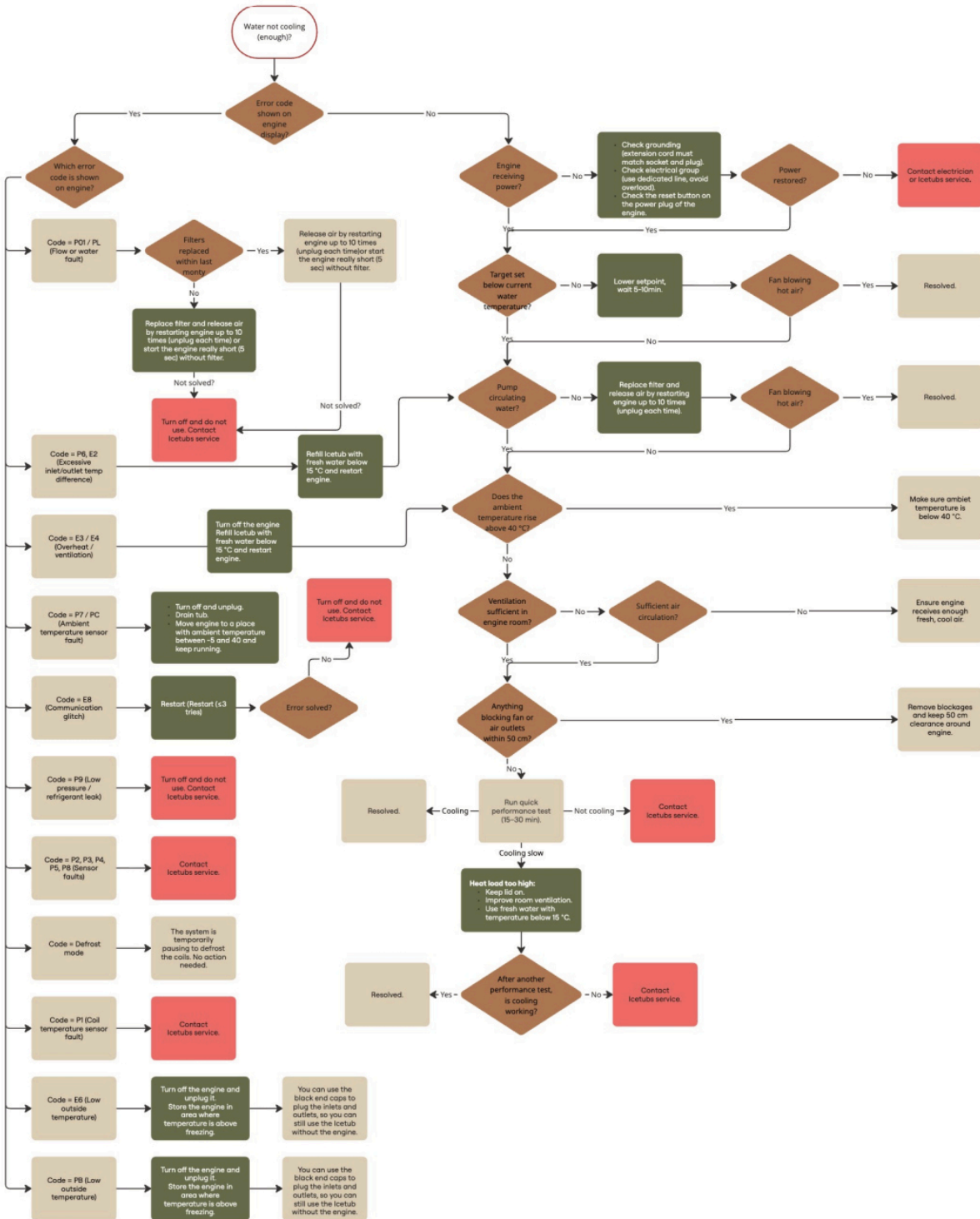

9.3 Troubleshooting “Problem with Water Level or Leaks”

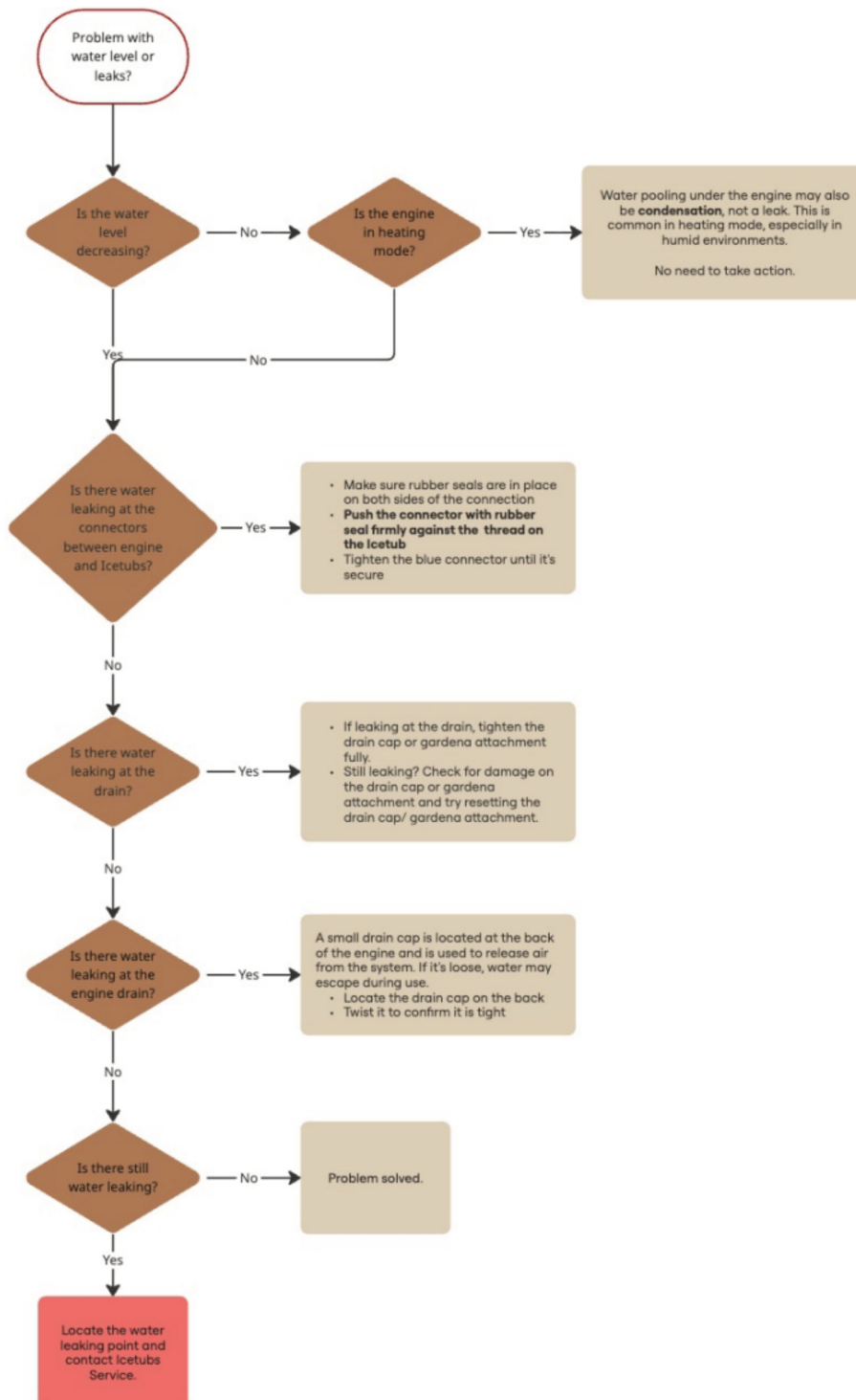

9.4 Troubleshooting “Water Quality not Good Enough”

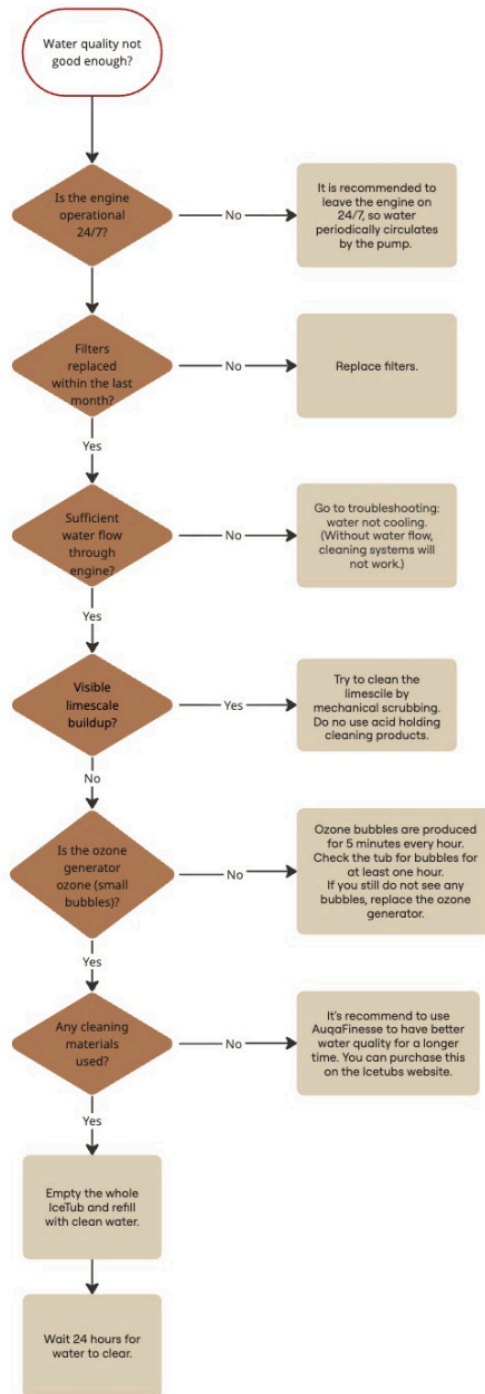

10 Warranty and Service

These terms outline the warranty coverage for Icetubs Consumer Products used for private and light professional purposes, ensuring safe operation and protecting both the customer and Icetubs B.V. This warranty is in addition to your statutory rights under EU/UK consumer protection laws and does not affect those rights.

10.1 Warranty

- Private use: 2-year warranty. Manufacturing defects and component failures under normal use (per EU/UK Consumer Law).
- Light professional use: 6-months warranty. Manufacturing defects for commercial/professional use.
- Consumables (Filters, Aquafinesse, Ozone generator and Water pump) are excluded.
- Consumers must report defects within two months of discovery. Light professional users must report within 14 days.
- Report transport damage within 24 hours of delivery, with photos/videos of the damaged packaging.
- Provide proof of purchase, description of the issue, photos/videos.
- Labor, travel, and call-out fees are not included

10.2 Approved use For Warranty

Warranty applies when:

- Installed with a grounded electrical setup, proper engine ventilation according to the installation guide, and placed on a level surface.
- Icetub + Cooling Engine must always be placed somewhere with an ambient temperature range of -5°C - 40°C with the engine on and within a range of 1°C - 40°C with the engine off.
- The engine must always have water inside when running, with a functional filter installed.
- Only the approved water treatments for the model are used (AquaFinesse).
- Filters are replaced with new ones on a monthly basis for private use and on a weekly basis for light professional use, when Icetub is operational.
- Icetubs installation guidelines are followed.

10.3 Warranty Exclusions

Warranty is void if any of the following occur:

- Exceeding usage limits (15 users/day, 3 users/hour)
- Operating in spaces below 1 °C or above 40 °C with engine off or below -5 °C or above 40 °C with engine on.

- Using any non-approved chemicals (salts, chlorine, magnesium, shock doses, flocculants, or DIY mixtures) might result in corrosion damage and will void your warranty coverage.
- Damage resulting from improper electrical setup, blocked ventilation, or placement on an uneven floor will void the warranty.
- The engine is running without water inside and/or without a functional filter installed.
- Any foreign objects (e.g. glasses, toys) are placed in the Icetub
- Corrosion damage due to **Coastal Placement** (within 20 km of the coast) or damage from fire, flood, theft, pests, or extreme weather voids the warranty.

The warranty does not cover:

- Consumables: Filters, Aquafinesse, Ozone generator and Water pump.
- Damage due to Negligence: Damage resulting from improper transport, relocation, or failure to follow installation/operation instructions.
- External Damage: Flooding, plumbing leaks, or external water ingress (damage originating from outside the unit).
- Misuse/Aesthetics: Cosmetic discoloration from chemical or mechanical misuse, personal injuries/accidents resulting from product misuse or damage resulting from unauthorized modifications.
- Natural Wear and Tear: Wood deterioration due to sun and weather exposure.

10.4 Service

Defective parts will be repaired or replaced free of charge, with refurbished replacements after three months.

- Exclusions: Labor and call-out charges are not covered, and customer cooperation is required for replacing simple parts.
- Repairs must be pre-approved by Icetubs, using only Icetubs approved parts. Unauthorized repairs void the warranty.

Warranty on Replaced Parts

- Replacing a part does not restart the original product warranty.
- Replaced parts remain covered for the remainder of the original product warranty.
- If a replaced part fails within the warranty period, we will repair or replace it with a refurbished part free of charge.
- Labor costs for removal, replacement, or installation are not covered.

Contact details:

 service@icetubs.com

 (+31) 33 200 3091

Address: Icetubs B.V. - Nieuwpoortkade 16, 1055 XG Amsterdam

Provide the following information:

- A clear description of the problem.
- The troubleshooting graph you used and which steps you completed.
- Photos or videos of the issue, if possible.

This information helps our service team assist you quickly and effectively.

10.5 Warranty Transferability

Icetubs B.V. products are built to last, and we support the circular economy. This warranty is tied to the product's serial number

and is transferable under the following conditions:

- **Transfer of Coverage:** The remaining balance of the original Warranty Period may be transferred to a second owner, provided the product remains within its original country of delivery.
- **Validation:** To validate a warranty claim, the new owner must provide the original proof of purchase (invoice) from Icetubs B.V. or an authorized dealer.
- **No Extension:** A transfer of ownership does not extend or restart the Warranty Period; it only allows the new owner to utilize the remaining time left on the original 2-year (Private) or 6-month (Professional) term.
- **Notification:** We strongly recommend that the original purchaser notifies service@icetubs.com of the change in ownership to update our records for seamless technical support.
- **Condition at Transfer:** Icetubs B.V. is not responsible for damage incurred during the decommissioning, transport, or re-installation of the unit by the secondary owner.

Operational Manual
Icetubs



www.icetubs.com

How to #JoinTheCold

Important to Know

- Always check the water temperature before stepping into the ice bath.
- Keep exposure time short, around 1–3 minutes, depending on the water temperature and your personal preferences.
- Children may only use the ice bath under adult supervision, with reduced exposure times and warmer temperatures.
- If you have a medical condition, such as heart disease, bad circulation, respiratory issues, or high blood pressure, seek medical advice before using an ice bath.
- Enter and exit the ice bath slowly to avoid slipping or falling. Do not jump, dive, or drop into the ice bath, as this can cause accidents or damage to the unit.

Before You Start

- Shower before you go into the ice bath to remove oils, lotions, or sweat from your skin that may compromise water quality.
- Make sure you're hydrated. Avoid drinking alcohol and eating heavy meals in the hour leading up to using the ice bath.
- Never use the ProBath alone. Having someone with you while you take an ice bath is crucial to supervise and ensure your experience stays safe.
- Enter the ice bath only when you are physically and mentally prepared for deliberate cold exposure: Decide consciously to enter: ensure your body and mind are ready for deliberate cold exposure.

After You've Joined The Cold

- Enter the bath slowly and gradually to minimize the risk of cold shock.
- Submerge your body up to the neck if possible, keeping your head completely above water at all times.
- A single ice bathing session should last 1–3 minutes. Limit immersion to a maximum of 5 minutes or exit sooner if discomfort increases.
- Focus on controlled exposure rather than pushing endurance. The goal is safe, manageable discomfort. Pay attention to how your body feels, as tolerance can vary day to day.

During Your Session

- Step out of the water slowly and carefully. Expect mild stiffness in your muscles and joints immediately after cold exposure.
- Pat your skin dry with a towel and avoid sharp temperature changes; warm up gradually.
- Wait until your heart rate and body temperature have returned to normal before considering a second session.
- Engage in some light exercise such as squats, horse stance, or light walking to promote circulation and warm the body safely.
- Feeling cold after a session is normal. Seek immediate medical attention if you experience severe shivering, numbness, disorientation, or loss of coordination – these may indicate hypothermia.

Contraindications & Risk Groups

Cold water immersion is not for everyone. Individuals with certain medical conditions should avoid using an ice bath unless cleared by a healthcare professional.

If you have any of the following pre-existing medical conditions or health concerns, please consult a doctor before using the ProBath. Your safety is always more important than a complete cold therapy session.

Medical Conditions

- Serious heart or cardiovascular, including uncontrolled high blood pressure.
- Circulatory disorders or other significant illnesses that may affect blood flow.
- Epilepsy, fainting disorders, or conditions that affect body temperature regulation.
- Raynaud's syndrome or peripheral neuropathy.
- Respiratory conditions such as asthma or chronic lung disease.
- Recent surgery or injuries – use the ProBath only with medical clearance.

Temporary Health Risks

- Fever, cold, flu, or any infectious illness.
- Open wounds, sores, or skin infections.
- Immediately after intense exercise. Allow the body to recover and cool down first.
- Within one hour after a heavy meal.
- Under the influence of alcohol or drugs.

Specific Groups

- Pregnant women, unless specifically approved by a healthcare professional.
- Children under 12 years old, unless medically advised and closely supervised.